

Drive Scan Drive Specialist

Low Voltage Devices

Manual

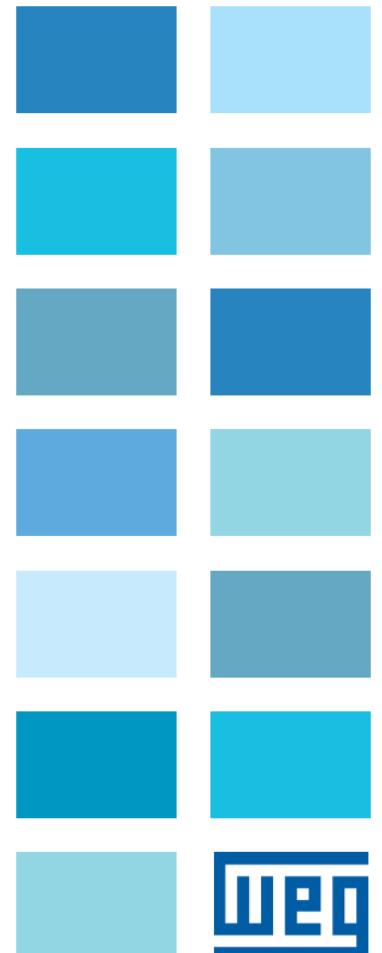



Manual

Series: Low Voltage Devices

Language: English

Document Number: 10009054128 / 02

Build 02

Products: CFW11, CFW100, CFW300, CFW500, CFW700, SRW01,
SSW900 and CFW11M

Publication Date: 10/2022

Summary of reviews

Version	Revision	Description
1.0x	00	First edition.
1.1x	01	General revision and Temperature Elevation chapter added.

Contents

1 INTRODUCTION	1-1
1.1 ABBREVIATIONS AND DEFINITIONS	1-1
1.2 OVERVIEW - Drive Scan AND DRIVE SPECIALIST	1-2
2 INSTALLATION RECOMMENDATIONS.....	2-0
2.1 INSPECTION ON RECEIPT	2-0
2.2 PHYSICAL INSTALLATION.....	2-0
3 WEG MOTION FLEET MANAGEMENT	3-1
3.1 FUNCTIONALITIES AND DOCUMENTATION	3-1
3.2 REGISTERING AN ASSET.....	3-1
4 Drive Scan COMMUNICATION.....	4-1
4.1 COMPATIBILITIES	4-1
4.2 COMMUNICATION INTERFACES AND PROTOCOLS.....	4-1
4.3 RS-485 CONNECTOR	4-1
4.4 NETWORK SETTINGS.....	4-2
4.5 NUMBER OF MONITORED ASSETS.....	4-2
4.6 INTERNET CONNECTION REQUIREMENTS	4-2
5 CONNECTING A DEVICE TO THE Drive Scan	5-0
5.1 RECOMMENDATIONS FOR CONNECTION VIA RS-485	5-0
5.2 MVW-01 FREQUENCY INVERTER	5-1
5.2.1 RS-485	5-1
5.2.2 ETHERNET	5-2
5.2.3 POSSIBLE FORMS OF CONNECTION	5-7
5.2.4 MONITORING	5-8
5.3 MVW3000 FREQUENCY INVERTER	5-10
5.3.1 RS-485	5-10
5.3.2 ETHERNET	5-11
5.3.3 POSSIBLE FORMS OF CONNECTION	5-16
5.3.4 MONITORING	5-17
5.4 SOFT-STARTER SSW7000	5-19
5.4.1 RS-485	5-19
5.4.2 ETHERNET	5-19
5.4.3 POSSIBLE FORMS OF CONNECTIONS	5-21
5.4.4 MONITORING	5-22
6 SETTING THE Drive Scan ON THE MFM	6-1
7 MONITORING DASHBOARD	7-1

7.1	ACCESS.....	7-1
7.2	FEATURES	7-1
7.3	PARAMETERS	7-1
A	SETTING THE IP ON WINDOWS 10	A-0

1 INTRODUCTION

This document covers the general concepts and configurations of Drive Scan and Motion Fleet Management for communication and monitoring of the WEG low voltage inverter line.

To complement the information contained in this document, please also refer to the contents related to the following documents:

- Manuals of the frequency inverters connected to the Drive Scan;
- Manuals of the CFW11, CFW100, CFW300 and CFW500, SRW01, SSW900 and CFW-11M devices;
- Manual of the WEG Motion Fleet Management platform.

All those manuals are available for download at the WEG website download center (www.weg.net).

Some procedures described are subject to changes that will not affect the user's understanding.

1.1 ABBREVIATIONS AND DEFINITIONS

- MFM WEG Motion Fleet Management. Cloud service platform used in WEG IoT applications.
- Drive Frequency inverter.
- Asset Dispositivo que normalmente possui um bom valor agregado (um inversor de frequência CFW11, por exemplo).
- Attribute An attribute usually consists of only one variable monitored by the Drive Scan published in the MFM, but there are situations where a variable is subdivided into more than one attribute, such as: last value, average value, minimum value and maximum value.
- DHCP Dynamic Host Configuration Protocol. Protocol that allows devices newly connected to a network to obtain an IP address automatically.
- DNS System responsible for translating IP addresses into domain names and vice versa.
- Ethernet Interconnection architecture for local area networks (IEEE 802.3).
- Firmware Set of operating instructions that are programmed directly into electronic equipment hardware.
- Gateway Electronic device that allows data flow between different communication networks.
- Hardware Equipment or device.
- IoT Internet of Things. Technology that allows machine-to-machine communication using an internet connection.
- IP Internet Protocol. Internet protocol for forwarding datagrams between networked devices.
- Login Action for the user to access the system. It is usually necessary to enter a username and password.
- Logout Action that terminates the user's connection to the system.
- MQTT Message Queuing Telemetry Transport. Transport protocol that uses the publish/subscribe architecture to transfer lightweight messages between devices.
- Pop-up Window smaller than a screen, which is over the main window.
- Plant Factory installation.
- RS-485 Interface standard for asynchronous serial communication.
- Site Set of plants.

- Software A program or set of instructions executed by a microcontroller or a microprocessor.
- URL Uniform Resource Locator. Web address of a resource available on a network.
- Web World Wide Web. Hypertextual system that operates over the internet.
- WLAN Wireless Local Area Network.

1.2 OVERVIEW - DRIVE SCAN AND DRIVE SPECIALIST

The Drive Scan consists of the Drive Scan gateway and the WEG Motion Fleet Management platform. It is designed to monitor information of different assets and assist in their maintenance.

The Drive Scan has dedicated firmware to integrate assets with the MFM platform, performing several important tasks, such as:

- Registration on the MFM platform;
- Reading of each connected asset;
- Processing of the read data;
- Data storage for up to 30 days in case of disconnection from the MFM;
- Publishing of sampled data on the MFM platform.
- It has smart code Drive Scan-DSLX-2P2SE-W-POE, item 15474014.

The Drive Specialist ([Chapter ??](#)) adds to the Drive Scan advanced diagnostic features and information about the CFW11 energy consumption.

2 INSTALLATION RECOMMENDATIONS

This manual contains the necessary information for the correct installation, configuration and use of the Drive Scan. The document was developed for professionals with suitable training or technical qualifications to operate this type of product. Failure to comply with the product instructions may cause operating accidents and damages to the device, in addition to voiding the warranty. The user is responsible for the correct definition of the environment and application characteristics.

2.1 INSPECTION ON RECEIPT

When you receive the Drive Scan, please check that the package contains the items listed below. Figure [Figure 2.1](#) shows the accessories contained in the package.

- 1x WCD Drive Scan,
- 2x WiFi antenna,
- 1x power supply 12V + 2x socket plug.

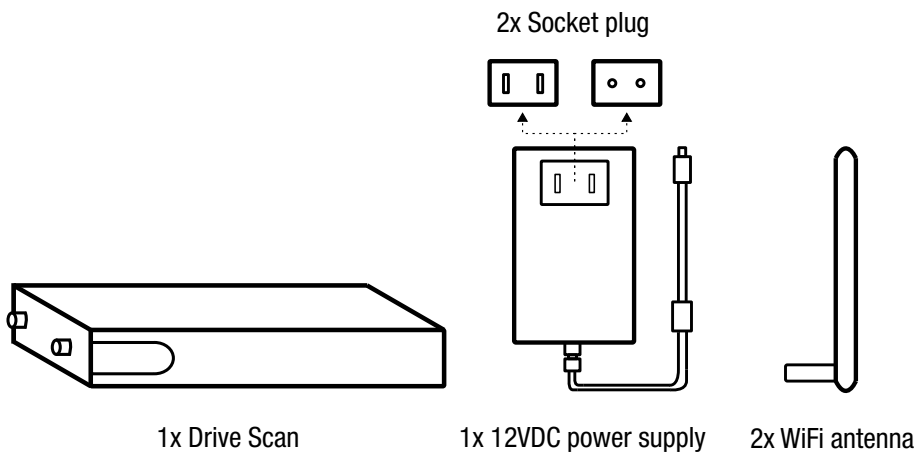

Figure 2.1: Drive Scan and Accessories

2.2 PHYSICAL INSTALLATION

Installing the Drive Scan is a simple task. Just follow the steps listed below.

1. Insert both antennas, one into each input.
2. Insert one of the power plugs (at your discretion) into the power supply and insert the cable into the Drive Scan power input.
3. Panel Installation:
 - a) Place the Drive Scan on the base of the panel and energize it through an outlet.
 - b) Or, if possible, snap the Drive Scan onto the DIN rail on the panel.

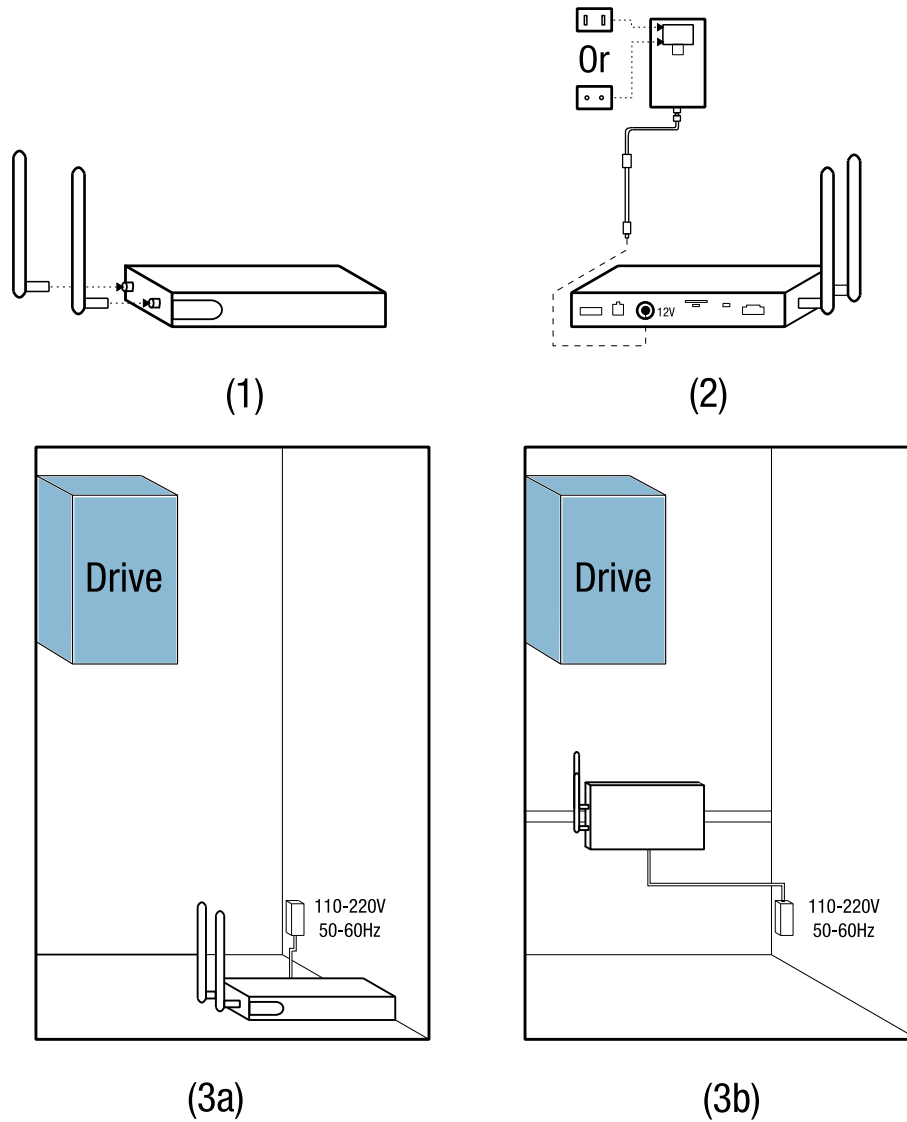

Figure 2.2: Instructions for the Drive Scan Physical Installation



WARNING!

Be sure to power the Drive Scan within 110V to 220V power range (with frequency from 50 to 60Hz).

Installation and configuration of the Drive Scan communication with WEG devices, as well as the platform configurations, are covered in the following chapters.



3 WEG MOTION FLEET MANAGEMENT

3.1 FUNCTIONALITIES AND DOCUMENTATION

The WEG Motion Fleet Management platform is WEG's IoT system that performs the user's interaction in a secure environment. Among other things, the platform main functions are:

- Account and user management;
- Plant and site edition;
- Subscription request;
- Asset registration;
- Presentation of each asset in dashboards;
- Presentation of performance indicators;
- Maintenance management;
- Complete health diagnostics of the asset (only with the Drive Specialist subscription for the CFW-11 frequency inverter);
- Estimation and prediction of variables through the Drive Specialist.

Access the WEG Motion Fleet management at <https://mfm.wnology.io>, fill out your registration and download the MFM guide. To that end, just select the "Guide" option from the "User" menu, located on the upper right corner of the page, as shown in [Figure 3.1](#).

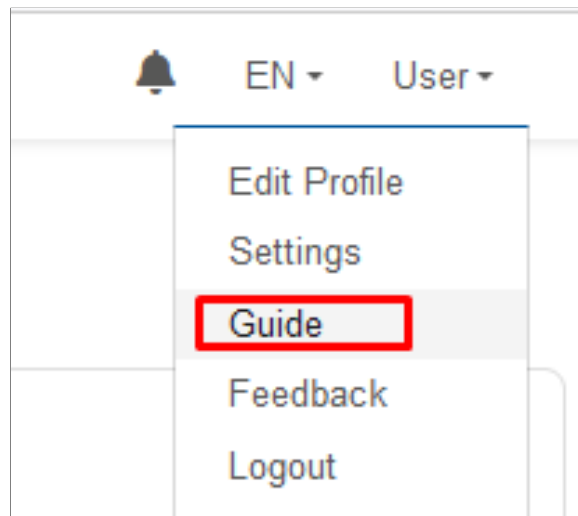

Figure 3.1: Access to the MFM manual

While reading the MFM guide, take the opportunity to organize the site and the plans. After that, you can register your assets on the platform. This will simplify the initial configuration of the Drive Scan, which will be detailed in [Chapter 6](#).

3.2 REGISTERING AN ASSET

Before registering an asset, it is necessary to register the Drive Scan on the WEG Motion Fleet Management platform, as explained in [Chapter 6](#).

Step 1

In the web browser, access the website <https://mfm.wnology.io>.

Enter your email and password and click on the “SIGN IN” button, as shown in [Figure 3.2](#).

If you don't have an account, create one through the “Sign up” link.

3

E-mail

Password

[Forgot your password?](#)

Don't have an account yet? [Sign up](#)

Figure 3.2: Accessing the WEG MFM platform

Step 2 Click on the menu and select the “REGISTER AND UPDATE” option.
Click on the “Device” option, as shown in Figure 3.3.

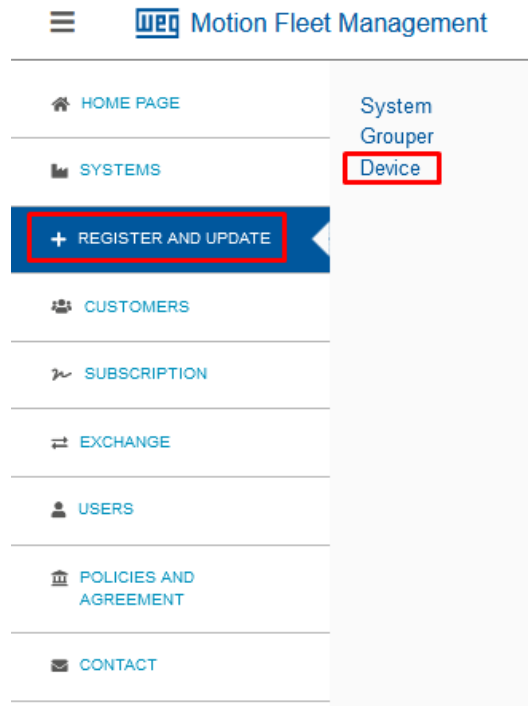

Figure 3.3: Registering a new device

Step 3 Click on “+DEVICES” button, as shown in Figure 3.4.



Figure 3.4: Adding a device

Step 4 Select the “Drive” option and click on the “Register” button, as shown in Figure 3.5.

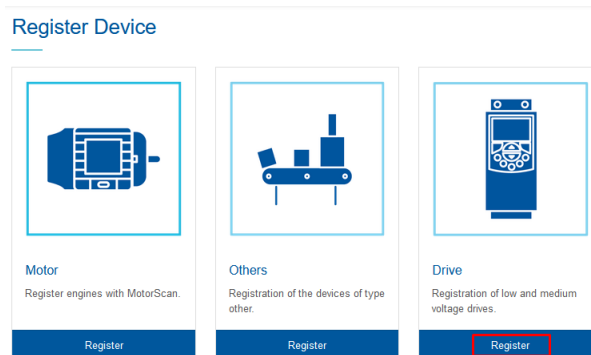

Figure 3.5: Adding a drive

Step 5



WARNING!

The Drive Scan must have been previously registered on the MFM, as described in [Chapter 6](#).

Select Drive Scan and click on the "CONTINUE" button, as shown in [Figure 3.6](#).

3

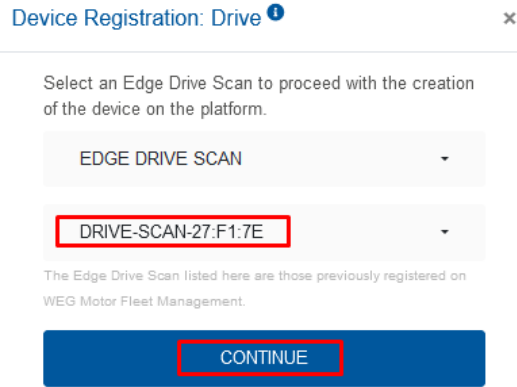

Figure 3.6: Adding a drive

Step 6

Click on the "+ADD" button, as shown in [Figure 3.7](#).

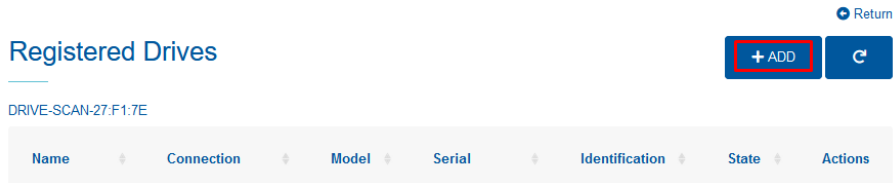

Figure 3.7: Adding a drive to the MFM

Step 7 Enter your device name.

Select your device connection mode to Drive Scan.

In [Figure 3.8](#), the RS-485 option was chosen. The following settings are related to this choice.

Drive Registration

Edge Drive Scan Status **Connected**

Name
MyCFW11

Drive connection mode on the Edge ⓘ
 Ethernet (ETH1) RS485

Drive Modbus Address (Unit ID)
1

Device Data: Identify

Model
CFW-11

Serial number
1234567890

SAVE CANCEL

Figure 3.8: Registering a drive

Set the drive ModBus address.

Select the device model (asset).

Enter the asset serial number.

Click on the “SAVE” button.

Step 8 Click on the name of your asset to view the dashboard, as shown in [Figure 3.9](#).

Registered Drives

+ ADD Return

DRIVE-SCAN-27:F1:7E

Name	Connection	Model	Serial	Identification	State	Actions
MyCFW11	UnitID:1	SRW-01	1234567890	-	Enabled	...

Showing 1 to 2 of 2 rows 25 rows per page

Figure 3.9: List of registered drives in the Drive Scan on the MFM

Step 9 A [Figure 3.10](#) shows the dashboard of the drive newly registered on the MFM.

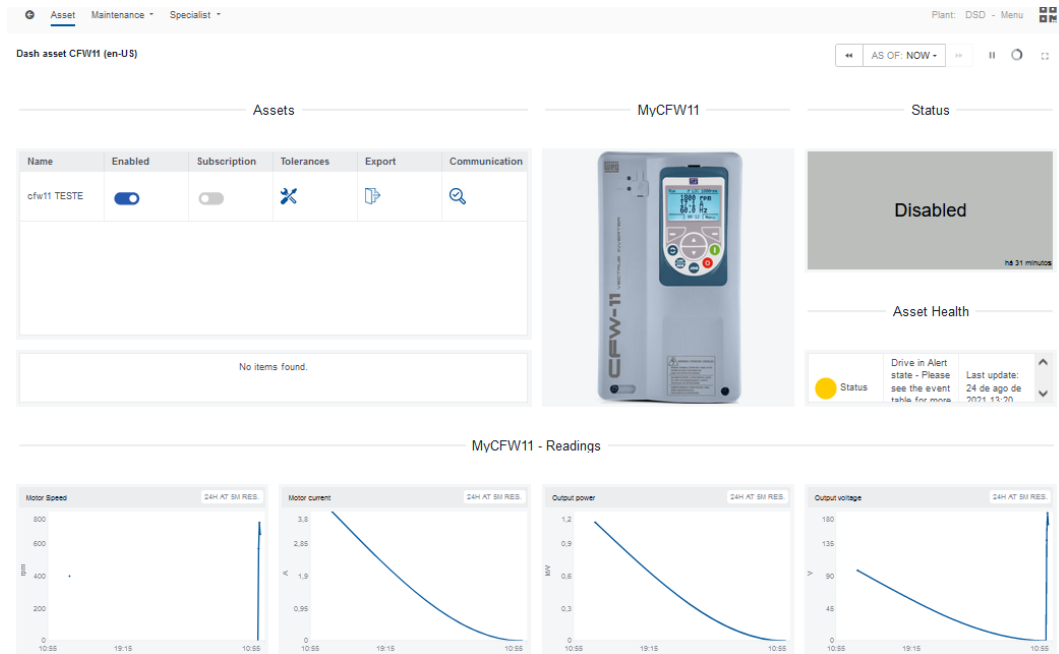

Figure 3.10: Dashboard of the drive registered on the MFM

4 DRIVE SCAN COMMUNICATION

4.1 COMPATIBILITIES

To establish communication between the Drive Scan and the inverter, make sure that each system has a suitable version. [Table 4.1](#) contains the version compatibilities of the Drive Scan system components.

Table 4.1: Version compatibility for the Drive Scan communication

	v0.0.1	v0.0.5	v0.0.8	v0.1.x	v0.3.x	v0.4.x	v0.5.x	v1.x.x			
Scan Application		x	x	x	x	x	x	x			
	v1.0.0	v1.1.0	v1.2.0	v1.3.0	v1.4.0	v1.5.0	v1.6.0	v1.7.0	v1.8.x	v1.9.x	2.x.x
WCD ED300 DSLV				x	x	x	x	x	x	x	x
	v1.0.0	v1.1.0	v1.1.7	v1.1.8	v1.1.9	v1.2.x	v1.6.0	v1.7.0	v1.8.x	v1.9.x	2.x.x
Wnology/Edge-Agent			x	x	x	x	x	x	x	x	x
	v1.0.xx	v1.1.xx	v1.2.xx	v1.3.xx	v1.4.xx	v1.5.xx	v1.6.0x	v1.7.0x	v1.8.xx	v1.9.xx	
Motion Fleet Management		x	x	x	x	x	x	x	x	x	

The compatibility of each product with the Drive Scan can be seen in their respective sections, in [Chapter 5](#).

4.2 COMMUNICATION INTERFACES AND PROTOCOLS

The Drive Scan Drive Scan connects to the assets by one of the following communication interfaces, according to [Figure 4.1](#):

- Ethernet port GbE1 (1), using Modbus-TCP protocol;
- RS-485 port (2), using Modbus-RTU protocol.



Figure 4.1: Drive Scan Drive Scan Communication Interfaces

4.3 RS-485 CONNECTOR

[Figure 4.2](#) describes the RS-485 connector pin signals.

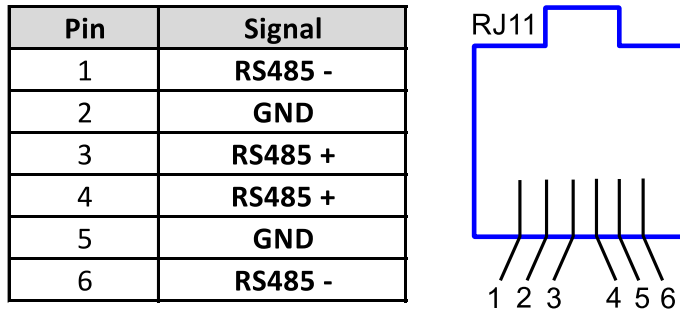

Figure 4.2: Drive Scan Scan Drive RS-485 Connector Signals

4.4 NETWORK SETTINGS

All the devices connected to physical networks, whether via RS-485 or Ethernet, must have the same baud rate, data bit, parity and stop bit settings, so that the respective network works correctly.

4.5 NUMBER OF MONITORED ASSETS

The Drive Scan Drive Scan allows connecting and monitoring up to 10 assets on the RS-485 network and up to 10 assets on the Ethernet network, for a maximum of 20 assets. Chapter 5 describes the settings and possible ways of connecting the low voltage frequency inverters to the Drive Scan.

. In the case of the SRW01, the Drive Scan Drive Scan allows connecting and monitoring up to 20 relays on the Ethernet network . Note: It is only possible to monitor the SRW01 on Ethernet models. Chapter ?? describes the settings and possible ways of connecting the relay to the Drive Scan.

4.6 INTERNET CONNECTION REQUIREMENTS

For the proper operation of the Drive Scan and connection to the MFM cloud, the customer’s network must meet some requirements and have some releases.

Note: to release the addresses, ports and internet access, ask the IT team in charge of the network.

- The user’s network must not have VPN or PROXY;
- The ports of Table 4.2 and the IP addresses of Table 4.3 must be accessible.

Table 4.2: Addresses required for the Drive Scan communication with the MFM

Destination	IP	Objective
broker.app.wnology.io	3.234.136.81	Send data to the MFM
*.wnology.io	3.227.206.235	Data exchange with mfm
api.app.wnology.io	52.22.246.163	MFM service requests
hub.docker.com	Dynamic address	Edge-Agent Maintenance
nexus3.weg.net	Dynamic address	Firmware update

Table 4.3: Ports required for the Drive Scan communication with the MFM

Protocol	Port	Objective
TCP	443	Update/Support the Drive Scan and Send data to the MFM
TCP	8883	

5 CONNECTING A DEVICE TO THE DRIVE SCAN

5.1 RECOMMENDATIONS FOR CONNECTION VIA RS-485

When connecting the Drive Scan to any WEG device via serial (RS-485), terminations must be provided at the external connection points. In cases where both ends are arranged on the CFW, SSW or MVW lines, their interfaces already have switches to enable the termination resistors.

In case the ED300 is at an end, it is recommended to use an external termination module, such as those listed below:

- PSB-TERMINATOR-PB-TBUS (Phoenix Contact);
- 6ES7972-6DA00-0AA0 (Siemens);
- AT303 (Smar)

5

Figure 5.1 illustrates the situation.

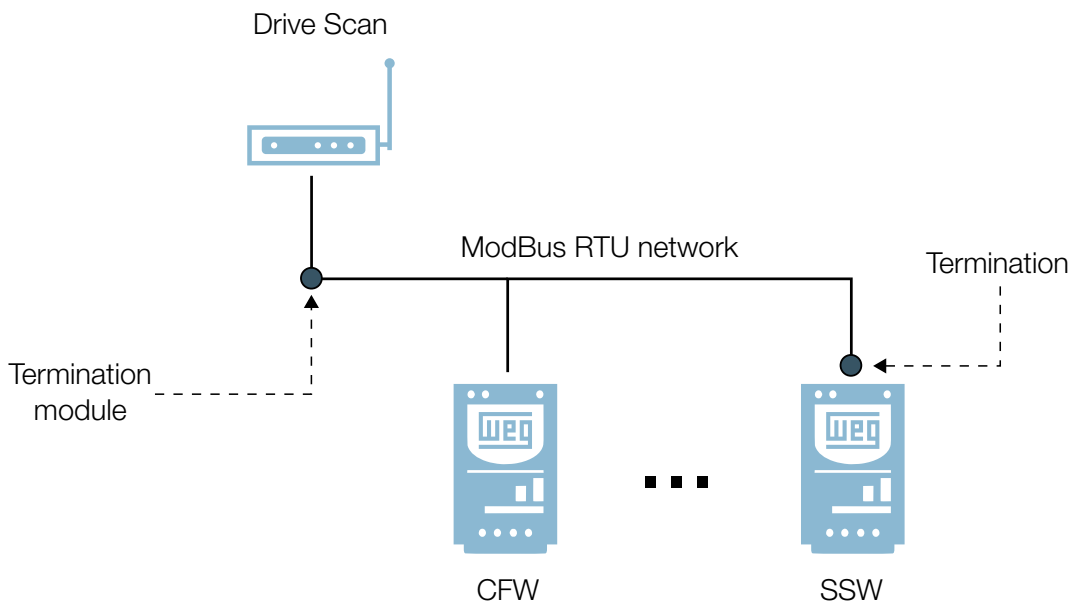

Figure 5.1: ModBus RTU network with Drive Scan at one end

5.2 CFW11 FREQUENCY INVERTER

5.2.1 RS-485

To connect the CFW11 to the Drive Scan via the RS-485 communication interface using the Modbus-RTU protocol, it is necessary to install on the CFW11 one of the accessories listed in [Table ??](#), observing the minimum allowed firmware version of the CFW11.

WEG's download center, which can be accessed at www.weg.net, is a channel that provides a wide range of documents about WEG equipment and accessories, as well as installation guides. For additional information about the CFW11 RS-485 communication "cfw11 rs485" and access the "CFW11 - RS-232/RS-485 Serial Communication Guide". For information about PLC11-01 and PLC11-02 settings and installation, search the download center for the keyword "PLC11".

It is very important to activate the termination resistors at the ends of the RS-485 network.

Table 5.1: RS-485 hardware accessories of the CFW11 compatible with Modbus RTU protocol





Accessory	WEG Item	Firmware CFW11	Parameters	Pin	Signal
RS485-01 	10051957	≥ V3.14	Table ??	1	Negative RxD/TxD
CAN/RS485-01 	10051960			2	Positive RxD/TxD
PLC11-01 	11008911			3	GND (Isolated 0V)
PLC11-02 	11094251			4	Shield
RS-485-05 	11008161	≥ V3.14	Table ??	XC31:8	Negative RxD/TxD
				XC31:9	Negative RxD/TxD
				1	+5V
				5	GND
				8	RxD/TxD
				9	RxD/TxD (inverted)

Table 5.2: Parameters related to the RS485-01, CAN/RS485-01 and RS485-05 accessories

Parameter	Description	Values range
P0308	Serial address	1 a 247
P0310	Serial baud rate	0 = 9600 bps 1 = 19200 bps 2 = 38400 bps 3 = 57600 bps
P0311	Serial interface byte configuration	0 = 8 bits, no parity, 1 stop bit 1 = 8 bits, even parity, 1 stop bit 2 = 8 bits, odd parity, 1 stop bit 3 = 8 bits, no parity, 2 stop bits 4 = 8 bits, even parity, 2 stop bits 5 = 8 bits, odd parity, 2 stop bits
P0312	Serial protocol	2 = Modbus RTU
P0313	Action for communication error	0 = Inactive 1 = Ramp stop 2 = General disable 3 = Go to LOCAL 4 = LOCAL holds enabled 5 = Fault cause
P0314	Serial Watchdog	0,0 a 999,0 s

Table 5.2: Parameters related to the RS485-01, CAN/RS485-01 and RS485-05 accessories

Parameter	Description	Values range
P0316	Serial interface status	0 = Inactive 1 = Active 2 = Watchdog error

Table 5.3: Parameters related to the PLC11-01 e PLC11-02 accessories

Parameter	Description	Values range
P1280	Serial protocol	1 = Modbus RTU (Slave)
P1281	Serial address	1 a 247
P1282	Serial baud rate	0 = 1200 bps 1 = 2400 bps 2 = 4800 bps 3 = 9600 bps 4 = 19200 bps 5 = 38400 bps
P1283	Serial communication configuration	0 = 8 bits, no parity, 1 stop bit 1 = 8 bits, even parity, 1 stop bit 2 = 8 bits, odd parity, 1 stop bit 3 = 8 bits, no parity, 2 stop bits 4 = 8 bits, even parity, 2 stop bits 5 = 8 bits, odd parity, 2 stop bits
P1284	Serial Watchdog	0,0 a 999,0 s

5

Figure ?? illustrates an RS-485 network among the CFW11 inverters, using all communication modules.

Figure ?? illustrates an RS-485 network among the CFW11 inverters, using all communication modules.

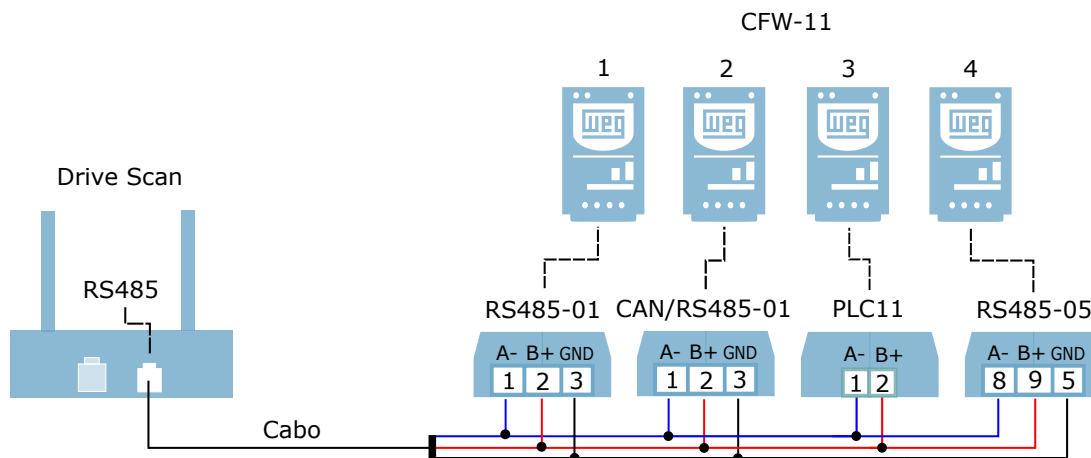

Figure 5.2: RS-485 network among several CFW11 and one Drive Scan

Note that the RS-485 signals (positive, negative and ground) of each inverter must share the same point or node. For example, the negative signals (A-) of inverters 1, 2, 3 and 4 must be connected to the same node. The same must be true for the positive (B+) and GND (if any) signals. It is important to remember that inverters in an RS-485 network must have different serial addresses.

5.2.2 ETHERNET

To connect to the Drive Scan via Ethernet GbE1 communication interface using the Modbus TCP protocol, it is necessary to install on the CFW11 one of the accessories listed in [Table 5.7](#). It is also important to observe the following settings in the table:

- The maximum number of clients connected simultaneously to the accessory;
- The minimum Drive Scan version compatible the with the CFW11 firmware.

For additional information, see the document “Anybus-CC Communication Modules” of the CFW11, which can be found in the download center at the website www.weg.net by searching for the keyword “anybus-cc”.

Table 5.4: Ethernet hardware accessories of the CFW11 compatible with the Modbus TCP protocol



Accessory	WEG item	Modbus TCP clients	CFW11 Firmware	Parameters
MODBUSTCP-05 (1 or 2 ports) 	11550476 (1P) 14033951 (2P)	up to 4	≥ V6.00	Table 5.8
ETHERNETIP-05 (1 or 2 ports) 	10933688 (1P) 12272760 (2P)	up to 2		
PROFINETIO-05 	11550548			

Table 5.5: Parameters related to the MODBUSTCP-05, ETHERNETIP-05 and PROFINETIO-05 accessories

Parameter	Description	Values range
P0723	Anybus identification	0 = Inactive 10 = RS485 19 = EtherNet/IP 21 = Modbus TCP 23 = PROFINET IO Other = Not compatible with Drive Scan
P0724	Anybus communication status	0 = Inactive 1 = Not supported 2 = Access error 3 = Offline 4 = Online
P0725	Anybus address	0 a 255
P0840	Anybus status	0 = Setup 1 = Init 2 = Wait Comm 3 = Idle 4 = Data Active 5 = Error 6 = Reserved 7 = Exception 8 = Access Error
P0841	Ethernet baud rate	0 = Auto 1 = 10 Mbps, half duplex 2 = 10 Mbps, full duplex 3 = 100 Mbps, half duplex 4 = 100 Mbps, full duplex
P0842	Modbus TCP timeout	0 a 655 s
P0843	IP address configuration	0 = Parameters 1 = DHCP 2 = DCP 3 = IPconfig
P0844	IP1 address	0 a 255

Table 5.5: Parameters related to the MODBUSTCP-05, ETHERNETIP-05 and PROFINETIO-05 accessories

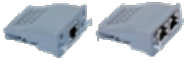
Parameter	Description	Values range
P0846	IP2 address	0 a 255
P0847	IP3 address	0 a 255
P0848	IP4 address	0 a 255
P0848	CIDR (subnet mask)	0 = Reserved 16 = 255.255.0.0 1 = 128.0.0.0 17 = 255.255.128.0 2 = 192.0.0.0 18 = 255.255.192.0 3 = 224.0.0.0 19 = 255.255.224.0 4 = 240.0.0.0 20 = 255.255.240.0 5 = 248.0.0.0 21 = 255.255.248.0 6 = 252.0.0.0 22 = 255.255.252.0 7 = 254.0.0.0 23 = 255.255.254.0 8 = 255.0.0.0 24 = 255.255.255.0 9 = 255.128.0.0 25 = 255.255.255.128 10 = 255.192.0.0 26 = 255.255.255.192 11 = 255.224.0.0 27 = 255.255.255.224 12 = 255.240.0.0 28 = 255.255.255.240 13 = 255.248.0.0 29 = 255.255.255.248 14 = 255.252.0.0 30 = 255.255.255.252 15 = 255.254.0.0 31 = 255.255.255.254
P0849	Gateway 1	0 a 255
P0850	Gateway 2	0 a 255
P0851	Gateway 3	0 a 255
P0852	Gateway 4	0 a 255

5

Figure ?? illustrates an Ethernet network among the CFW11 inverters using all the communication modules.

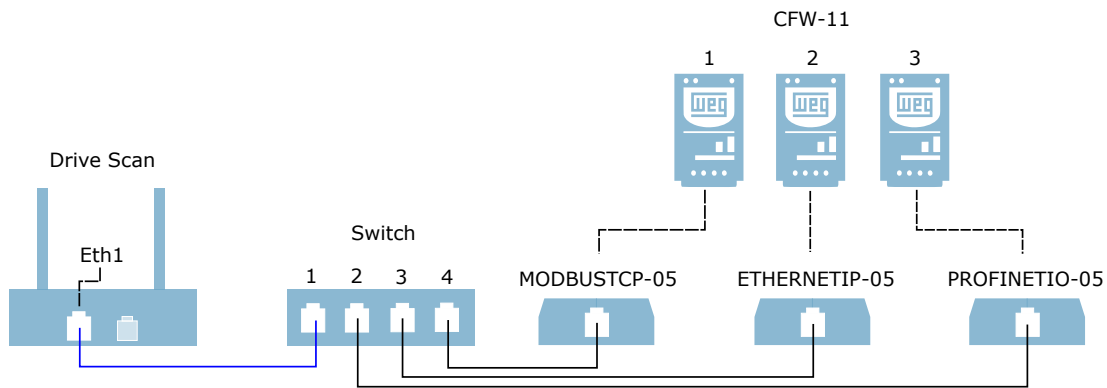

Figure 5.3: Ethernet network among several CFW11 and a Drive Scan

Note that to establish a network with more than one inverter, it is necessary to use a switch. It is important to remember that the inverters in an Ethernet network must have different IP values.

5.2.3 POSSIBLE FORMS OF CONNECTIONS

Figure ?? illustrates the possible ways to connect the CFW11 to the Drive Scan.

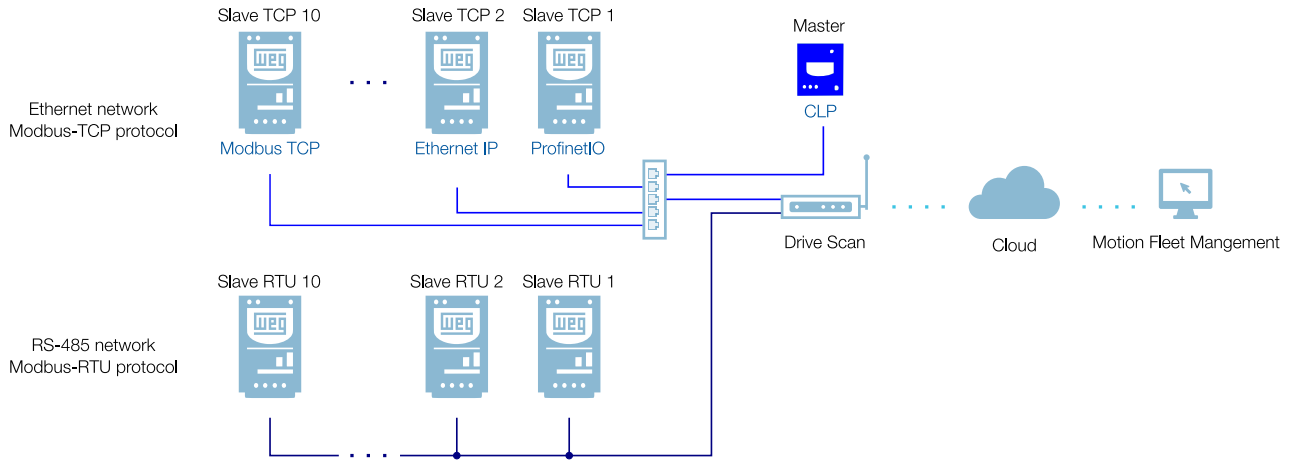

Figure 5.4: Possible connections with the CFW11



WARNING!

The Drive Scan can only be connected to the internet using the Ethernet port GbE0 if the network does not have a proxy.

5.2.4 MONITORING

The Drive Scan continuously monitors the CFW11 parameters specified in [Section ?? ?? on page ??](#) . After a cycle of all those readings, as well as of the other assets connected to the Drive Scan, a new reading cycle starts automatically.

The parameters read are transformed into attributes, which can be:

- Only at initialization;
- Last value read;
- Average value;
- Minimum value;
- Maximum value.

Every 5 minutes, the Drive Scan publishes the attributes to the WEG Fleet Management platform. In case of an internet connection failure, the Drive Scan stores the data for up to 30 days in the internal memory, publishing it to the MFM when the connection is reestablished.

In case the CFW11 fails, the Drive Scan automatically publishes the parameters specified in [Section ?? ?? on page ??](#) asynchronously, that is, without waiting for the normal cyclical period of publication.



5.2.4.1 Attributes Cyclically Monitored by the CFW11

Parameter	Description	Attribute	Acquisition type	Class	
P0202	Control type	controlType	Initialization	identification	
P0295	Inverter rated current	inverterRatedCurrent	Initialization		
P0296	Inverter rated voltage	inverterRatedVoltage	Initialization		
P0401	Motor rated current	motorRatedCurrent	Initialization		
P0402	Motor rated speed	motorRatedSpeed	Initialization		
P0400	Motor rated voltage	motorRatedVoltage	Initialization		
P0023	Software version	softwareVersion	Initialization		
P0297	Switching frequency	switchingFrequency	Initialization		
P0001	Motor speed reference	motorSpeedReferenceAvg	Average	status	
P0680	Status word	statusWord	Last value		
P0043	Enabled hours	enabledHours	Last value	diagnostic	
P0042	Energized hours	energizedHours	Last value		
P0048	Present alarm	presentAlarm	Last value		
P0049	Present fault	presentFault	Last value		
P0004	DC link voltage	dcLinkVoltageAvg dcLinkVoltageMin dcLinkVoltageMax	Average Minimum value Maximum value	measurement	
P0044	Energy counter	energyCounterAvg	Average		
P0036	Fan speed	fanSpeed	Last value		
P0003	Motor current	motorCurrentAvg motorCurrentMin motorCurrentMax	Average Minimum value Maximum value		
P0005	Motor frequency	motorFrequencyAvg motorFrequencyMin motorFrequencyMax	Average Minimum value Maximum value		
P0037	Motor overload	motorOverloadAvg motorOverloadMin motorOverloadMax	Average Minimum value Maximum value		
P0002	Motor speed	motorSpeedAvg	Average		
P0009	Motor torque	motorTorqueAvg motorTorqueMin motorTorqueMax	Average Minimum value Maximum value		
P0007	Motor voltage	motorVoltageAvg motorVoltageMin motorVoltageMax	Average Minimum value Maximum value		
P0010	Output power	outputPowerAvg outputPowerMin outputPowerMax	Average Minimum value Maximum value		
P0011	Output power factor	outputPowerFactor	Last value		
P0034	Air temperature	airTemperatureAvg	Average		temperature
P0035	Control temperature	controlTemperatureAvg	Average		
P0030	Phase U temperature	phaseUTemperatureAvg	Average		
P0031	Phase V temperature	phaseVTemperatureAvg	Average		
P0032	Phase W temperature	phaseWTemperatureAvg	Average		
P0033	Rectifier temperature	rectifierTemperatureAvg	Average		
P0018	Analog input 1	analogInput1	Last value	io	
P0019	Analog input 2	analogInput2	Last value		
P0020	Analog input 3	analogInput3	Last value		
P0021	Analog input 4	analogInput4	Last value		
P0014	Analog output 1	analogOutput1	Last value		
P0015	Analog output 2	analogOutput2	Last value		
P0016	Analog output 3	analogOutput3	Last value		
P0017	Analog output 4	analogOutput4	Last value		
P0012	Digital inputs	digitalInputs	Last value		
P0013	Digital outputs	digitalOutputs	Last value		

5.2.4.2 Attributes Monitored in Events by the CFW11

Parâmetro	Description	Attribute	Acquisition type	Class
P0090	Current at Last Fault	faultCurrent	Last value	Event
P0091	DC Link at Last Fault	faultCC	Last value	Event
P0092	Speed at Last Fault	faultVelocity	Last value	Event
P0093	Reference at Last Fault	faultReference	Last value	Event
P0094	Frequency at Last Fault	faultFrequency	Last value	Event
P0095	Motor Voltage at Last Fault	faultVoltageMotor	Last value	Event
P0096	Digital Input States at Last Fault Falha	faultDI	Last value	Event

5.3 CFW100 FREQUENCY INVERTER

5.3.1 RS-485

To connect the CFW100 to the Drive Scan via the RS-485 communication interface using the Modbus-RTU protocol, it is necessary to install on the CFW100 the accessory listed in [Table ??](#). The supported CFW100 firmware versions are v1.0 and above.

Refer to the CFW100 RS-485 Serial Communication guide, which can be obtained from the download center at www.weg.net, for additional information.

It is important to note that there is no Ethernet communication support for the CFW100.

Table 5.6: RS-485 hardware accessory of the CFW100 compatible with the Modbus RTU protocol

Accessory	WEG item	Parameters	A signal pin (-)	B signal pin (+)	GND signal pin
CRS485 	11710626	Table ??	6	7	8

Table 5.7: Parameters related to the RS-485 communication accessories

Parameter	Description	Values range
P0308	Serial address	1 a 247
P0310	Serial baud rate	0 = 9600 bps 1 = 19200 bps 2 = 38400 bps
P0311	Serial interface byte configuration	0 = 8 bits, no parity, 1 stop bit 1 = 8 bits, even parity, 1 stop bit 2 = 8 bits, odd parity, 1 stop bit 3 = 8 bits, no parity, 2 stop bits 4 = 8 bits, even parity, 2 stop bits 5 = 8 bits, odd parity, 2 stop bits
P0312	Serial protocol	2 = Modbus RTU
P0313	Action for communication error	0 = Inactive 1 = Ramp stop 2 = General disable 3 = Go to local 4 = Go to local and holds command and reference 5 = Fault cause
P0314	Serial watchdog	0,0 a 999,0 s
P0316	Serial interface status	0 = Inactive 1 = Active 2 = Watchdog error

5.3.2 POSSIBLE FORMS OF CONNECTIONS

[Figure ??](#) illustrates the possible ways to connect the CFW100 to the Drive Scan.

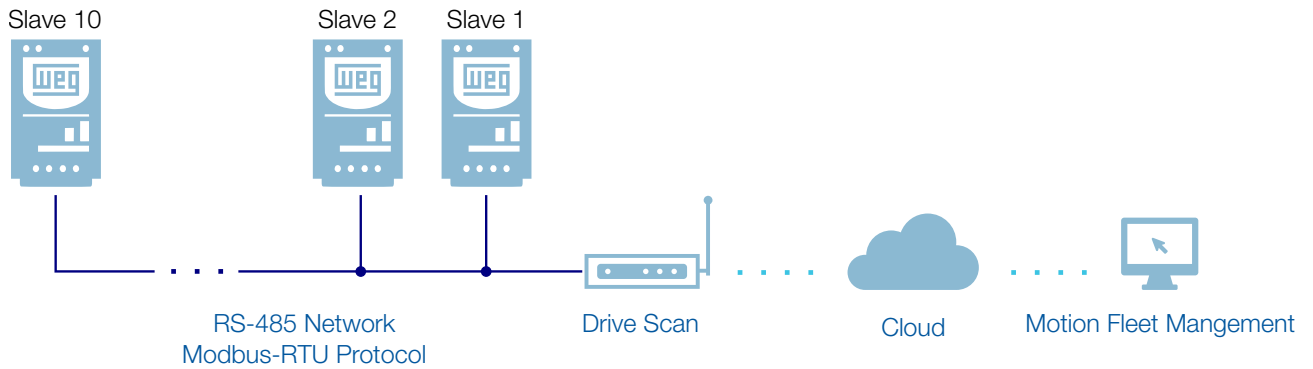

Figure 5.5: Possible connections to the CFW100



WARNING!

The Drive Scan can only be connected to the internet using the Ethernet port GbE0 if it does not have a proxy.

5.3.3 MONITORING

The Drive Scan continuously monitors the CFW100 parameters specified in [Section ?? ?? on page ??](#) . After a cycle of all these readings, as well as of the other assets connected to the Drive Scan, a new reading cycle starts automatically.

The parameters read are transformed into attributes, which can be:

- Only at initialization;
- Last value read;
- Average value;
- Minimum value;
- Maximum value.

Every 5 minutes, the Drive Scan publishes the attributes to the WEG Fleet Management platform. In case of an internet connection failure, the Drive Scan stores the data for up to 30 days in the internal memory, publishing it to the MFM when the connection is reestablished.

In case the CFW100 fails, the Drive Scan automatically publishes the parameters specified in [Section ?? ?? on page ??](#) asynchronously, that is, without waiting for the normal cyclical period of publication.

5.3.3.1 Attributes Cyclically Monitored by the CFW100

Parâmetro	Descrição	Atributo	Tipo de aquisição	Classe
P0202	Control type	controlType	Inicialização	identification
P0295	Inverter rated current	inverterRatedCurrent	Inicialização	
P0296	Inverter rated voltage	inverterRatedVoltage	Inicialização	
P0401	Motor rated current	motorRatedCurrent	Inicialização	
P0402	Motor rated speed	motorRatedSpeed	Inicialização	
P0400	Motor rated voltage	motorRatedVoltage	Inicialização	
P0023	Software version	softwareVersion	Inicialização	
P0297	Switching frequency	switchingFrequency	Inicialização	
P0001	Motor speed reference	motorSpeedReferenceAvg	Valor médio	status
P0680	Status word	statusWord	Último valor	
P0042	Enabled hours	enabledHours	Último valor	diagnostic
P0048	Present alarm	presentAlarm	Último valor	
P0049	Present fault	presentFault	Último valor	
P0004	DC link voltage	dcLinkVoltageAvg dcLinkVoltageMin dcLinkVoltageMax	Valor médio Valor mínimo Valor máximo	measurement
P0003	Motor current	motorCurrentAvg motorCurrentMin motorCurrentMax	Valor médio Valor mínimo Valor máximo	
P0005	Motor frequency	motorFrequencyAvg motorFrequencyMin motorFrequencyMax	Valor médio Valor mínimo Valor máximo	
P0037	Motor overload	motorOverloadAvg motorOverloadMin motorOverloadMax	Valor médio Valor mínimo Valor máximo	
P0002	Motor speed	motorSpeedAvg	Valor médio	
P0009	Motor torque	motorTorqueAvg motorTorqueMin motorTorqueMax	Valor médio Valor mínimo Valor máximo	
P0007	Motor voltage	motorVoltageAvg motorVoltageMin motorVoltageMax	Valor médio Valor mínimo Valor máximo	
P0010	Output power	outputPowerAvg outputPowerMin outputPowerMax	Valor médio Valor mínimo Valor máximo	
P0030	Module temperature	moduleTemperatureAvg	Valor médio	temperature
P0018	Analog input 1	analogInput1	Último valor	io
P0019	Analog input 2	analogInput2	Último valor	
P0014	Analog output 1	analogOutput1	Último valor	
P0015	Analog output 2	analogOutput2	Último valor	
P0012	Digital inputs	digitalInputs	Último valor	
P0013	Digital outputs	digitalOutputs	Último valor	

5.3.3.2 Attributes Monitored in Events by the CFW100

Parâmetro	Description	Attribute	Acquisition type	Class
P0090	Current at Last Fault	faultCurrent	Last value	Event
P0091	DC Link at Last Fault	faultCC	Last value	Event
P0092	Speed at Last Fault	faultVelocity	Last value	Event
P0093	Reference at Last Fault	faultReference	Last value	Event
P0094	Frequency at Last Fault	faultFrequency	Last value	Event
P0095	Motor Voltage at Last Fault	faultVoltageMotor	Last value	Event
P0096	Digital Input States at Last Fault Falha	faultDI	Last value	Event

5.4 CFW300 FREQUENCY INVERTER

5.4.1 RS-485

To connect the CFW300 to the Drive Scan via the RS-485 communication interface using the Modbus-RTU protocol, it is necessary to install on the CFW300 the accessory listed in [Table ??](#). The supported CFW300 firmware versions are v1.0 and above.

Refer to the CFW300 RS-485 Serial Communication guide, which can be obtained from the download center at www.weg.net, for additional information.

It is important to note that there is no Ethernet communication support for the CFW300.

Table 5.8: RS-485 hardware accessory of the CFW300 compatible with the Modbus RTU protocol

Accessory	WEG item	Parameters	A signal pin (-)	B signal pin (+)	GND signal pin
CRS485 	14742132	Table ??	25	26	27

Table 5.9: Parameters related to the RS-485 communication accessories

Parameter	Description	Values range
P0308	Serial address	1 a 247
P0310	Serial baud rate	0 = 9600 bps 1 = 19200 bps 2 = 38400 bps
P0311	Serial interface byte configuration	0 = 8 bits, no parity, 1 stop bit 1 = 8 bits, even parity, 1 stop bit 2 = 8 bits, odd parity, 1 stop bit 3 = 8 bits, no parity, 2 stop bits 4 = 8 bits, even parity, 2 stop bits 5 = 8 bits, odd parity, 2 stop bits
P0312	Serial protocol	2 = Modbus RTU
P0313	Action for communication error	0 = Inactive 1 = Ramp stop 2 = General disable 3 = Go to local 4 = Go to local and holds command and reference 5 = Fault cause
P0314	Serial watchdog	0,0 a 999,0 s
P0316	Serial interface status	0 = Inactive 1 = Active 2 = Watchdog error

5.4.2 ETHERNET

To connect to the Drive Scan via Ethernet GbE1 communication interface using the Modbus TCP protocol, it is necessary to install on the CFW300 the accessory CETH listed in [Table ??](#).

Table 5.10: Ethernet hardware accessory of the CFW300 compatible with the Modbus TCP protocol

Accessory	WEG item	Modbus TCP clients	CFW300 firmware	Parameters
CETH 	14409620	up to 4	≥ V3.00	Table ??

Table 5.11: Parameters related to the CETH accessories

Parameter	Description	Values range
P0850	IP address configuration	0 = Parameters 1 = DHCP
P0851	IP1 address	0 a 255
P0852	IP2 address	0 a 255
P0853	IP3 address	0 a 255
P0854	IP4 address	0 a 255
P0855	CIDR (subnet mask)	0 = Reserved 16 = 255.255.0.0 1 = 128.0.0.0 17 = 255.255.128.0 2 = 192.0.0.0 18 = 255.255.192.0 3 = 224.0.0.0 19 = 255.255.224.0 4 = 240.0.0.0 20 = 255.255.240.0 5 = 248.0.0.0 21 = 255.255.248.0 6 = 252.0.0.0 22 = 255.255.252.0 7 = 254.0.0.0 23 = 255.255.254.0 8 = 255.0.0.0 24 = 255.255.255.0 9 = 255.128.0.0 25 = 255.255.255.128 10 = 255.192.0.0 26 = 255.255.255.192 11 = 255.224.0.0 27 = 255.255.255.224 12 = 255.240.0.0 28 = 255.255.255.240 13 = 255.248.0.0 29 = 255.255.255.248 14 = 255.252.0.0 30 = 255.255.255.252 15 = 255.254.0.0 31 = 255.255.255.254
P0856	Gateway 1	0 a 255
P0857	Gateway 2	0 a 255
P0858	Gateway 3	0 a 255
P0859	Gateway 4	0 a 255
P0860	MBTCP: communication status	0 = Inactive 1 = No connection 2 = Connected 3 = Timeout error
P0863	MBTCP: Active connections	0 a 4
P0865	MBTCP: TCP port	0 a 9999
P0868	MBTCP: Timeout	0 a 999,9s
P0806	Modbus TCP Watchdog	0 a 65,5 s

5.4.3 POSSIBLE FORMS OF CONNECTIONS

Figure ?? illustrates the possible ways to connect the CFW300 to the Drive Scan.

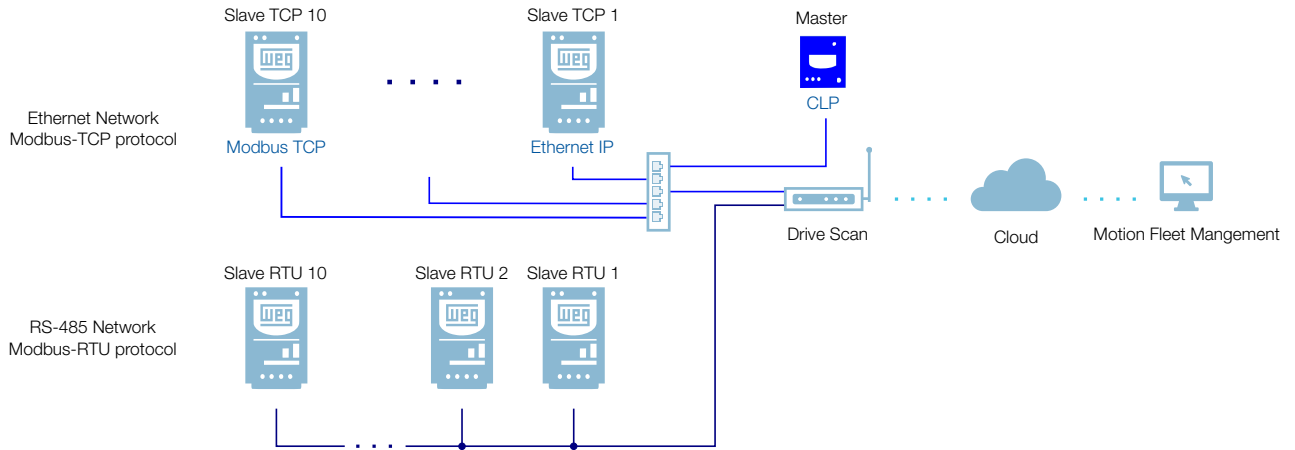

Figure 5.6: Possible connections to the CFW300



WARNING!

The Drive Scan can only be connected to the internet using the Ethernet port GbE0 if it does not have a proxy.

5.4.4 MONITORING

The Drive Scan continuously monitors the CFW300 parameters specified in [Section ?? ?? on page ??](#) . After a cycle of all these readings, as well as of the other assets connected to the Drive Scan, a new reading cycle starts automatically.

The parameters read are transformed into attributes, which can be:

- Only at initialization;
- Last value read;
- Average value;
- Minimum value;
- Maximum value.

Every 5 minutes, the Drive Scan publishes the attributes to the WEG Fleet Management platform. In case of an internet connection failure, the Drive Scan stores the data for up to 30 days in the internal memory, publishing it to the MFM when the connection is reestablished.

In case the CFW300 fails, the Drive Scan automatically publishes the parameters specified in [Section ?? ?? on page ??](#) asynchronously, that is, without waiting for the normal cyclical period of publication.

5.4.4.1 Attributes Cyclically Monitored by the CFW300

Parâmetro	Descrição	Atributo	Tipo de aquisição	Classe
P0202	Control type	controlType	Inicialização	identification
P0295	Inverter rated current	inverterRatedCurrent	Inicialização	
P0296	Inverter rated voltage	inverterRatedVoltage	Inicialização	
P0401	Motor rated current	motorRatedCurrent	Inicialização	
P0402	Motor rated speed	motorRatedSpeed	Inicialização	
P0400	Motor rated voltage	motorRatedVoltage	Inicialização	
P0023	Software version	softwareVersion	Inicialização	
P0297	Switching frequency	switchingFrequency	Inicialização	
P0001	Motor speed reference	motorSpeedReferenceAvg	Valor médio	status
P0680	Status word	statusWord	Último valor	
P0042	Enabled hours	enabledHours	Último valor	diagnostic
P0048	Present alarm	presentAlarm	Último valor	
P0049	Present fault	presentFault	Último valor	
P0004	DC link voltage	dcLinkVoltageAvg dcLinkVoltageMin dcLinkVoltageMax	Valor médio Valor mínimo Valor máximo	measurement
P0003	Motor current	motorCurrentAvg motorCurrentMin motorCurrentMax	Valor médio Valor mínimo Valor máximo	
P0005	Motor frequency	motorFrequencyAvg motorFrequencyMin motorFrequencyMax	Valor médio Valor mínimo Valor máximo	
P0037	Motor overload	motorOverloadAvg motorOverloadMin motorOverloadMax	Valor médio Valor mínimo Valor máximo	
P0002	Motor speed	motorSpeedAvg	Valor médio	
P0009	Motor torque	motorTorqueAvg motorTorqueMin motorTorqueMax	Valor médio Valor mínimo Valor máximo	
P0007	Motor voltage	motorVoltageAvg motorVoltageMin motorVoltageMax	Valor médio Valor mínimo Valor máximo	
P0010	Output power	outputPowerAvg outputPowerMin outputPowerMax	Valor médio Valor mínimo Valor máximo	
P0030	Module temperature	moduleTemperatureAvg	Valor médio	temperature
P0018	Analog input 1	analogInput1	Último valor	io
P0019	Analog input 2	analogInput2	Último valor	
P0014	Analog output 1	analogOutput1	Último valor	
P0015	Analog output 2	analogOutput2	Último valor	
P0012	Digital inputs	digitalInputs	Último valor	
P0013	Digital outputs	digitalOutputs	Último valor	

5.4.4.2 Attributes Monitored in Events by the CFW300

Parâmetro	Description	Attribute	Acquisition type	Class
P0090	Current at Last Fault	faultCurrent	Last value	Event
P0091	DC Link at Last Fault	faultCC	Last value	Event
P0092	Speed at Last Fault	faultVelocity	Last value	Event
P0093	Reference at Last Fault	faultReference	Last value	Event
P0094	Frequency at Last Fault	faultFrequency	Last value	Event
P0095	Motor Voltage at Last Fault	faultVoltageMotor	Last value	Event
P0096	Digital Input States at Last Fault Falha	faultDI	Last value	Event

5.5 CFW500 FREQUENCY INVERTER

5.5.1 RS-485

To connect the CFW500 to the Drive Scan via the RS-485 communication interface using the Modbus-RTU protocol, it is necessary to install on the CFW100 the accessory listed in [Table ??](#). The supported CFW500 firmware versions are v2.0 and above.

Refer to the CFW500 RS-485 Serial Communication guide, which can be obtained from the download center at www.weg.net, for additional information.



WARNING!

The CRS485-B accessory has an additional RS-485 interface. The default interface consists of the signals from pins 12 (A), 14 (B) and 16 (GND). The second interface consists of the signals from pins 20 (A), 22 (B) and 24 (GND).

Table 5.12: RS-485 hardware accessories of the CFW500 compatible with Modbus RTU protocol













Accessory	WEG Item	Parameters	A signal pin (-)	B signal pin (+)	GND signal pin
CRS485-B 	14742132	Table ??	12 e 20	14 e 22	16 e 24
IOS 	14741859		14	16	18
CCAN 	14741999		10	12	14
CRS232 	14742005		10	12	4
CPDP 	14742132		8	10	12
CPDP2 	12443605				
IOD 	14742006				
IOAD 	14742129				
IOR-B 	14742003		12	14	16
ENC 	12619000				
CUSB 	14742001				
CETH-IP 	12892614				
CEMB-TC	12892815		8	10	11
CEPN-IO	12892816				

Table 5.13: Parameters related to the RS-485 communication accessories

Parameter	Description	Values range
P0308	Serial address	1 a 247
P0310	Serial baud rate	0 = 9600 bps 1 = 19200 bps 2 = 38400 bps

Table 5.13: Parameters related to the RS-485 communication accessories

Parameter	Description	Values range
P0311	Serial interface byte configuration	0 = 8 bits, no parity, 1 stop bit 1 = 8 bits, even parity, 1 stop bit 2 = 8 bits, odd parity, 1 stop bit 3 = 8 bits, no parity, 2 stop bits 4 = 8 bits, even parity, 2 stop bits 5 = 8 bits, odd parity, 2 stop bits
P0312	Serial protocol	2 = Modbus RTU
P0313	Action for communication error	0 = Inactive 1 = Ramp stop 2 = General disable 3 = Go to local 4 = Go to local e mantém comandos e referência 5 = Fault cause
P0314	Serial watchdog	0,0 a 999,0 s
P0316	Serial interface status	0 = Inactive 1 = Active 2 = Watchdog error

5

5.5.2 ETHERNET

To connect to the Drive Scan via Ethernet GbE1 communication interface, using the Modbus TCP protocol, it is necessary to install on the CFW500 one of the accessories listed in [Table ??](#).

Table 5.14: Ethernet hardware accessories of the CFW500 compatible with the Modbus TCP protocol

Accessory	WEG Item	Modbus TCP clients	Firmware CFW500	Parameters
CETH-IP	 12892814	2	≥ V2.00	Table ??
CEMB-TCP		4		

Table 5.15: Parameters related to the CETH-IP and CEMB-TC accessories

Parameter	Description	Values range
P0800	Ethernet module identification	0 = Not identified 1 = Modbus TCP 2 = Ethernet/IP 3 = PROFINET IO
P0801	Ethernet communication status	0 = Setup 1 = Init 2 = Wait Comm 3 = Idle 4 = Data Active 5 = Error 6 = Reservado 7 = Exception 8 = Access Error
P0803	Ethernet baud rate	0 = Auto 1 = 10 Mbps, half duplex 2 = 10 Mbps, full duplex 3 = 100 Mbps, half duplex 4 = 100 Mbps, full duplex
P0806	Modbus TCP watchdog	0 a 65,5 s
P0810	IP address configuration	0 = Parameters 1 = DHCP

Table 5.15: Parameters related to the CETH-IP and CEMB-TC accessories

Parameter	Description	Values range																																
P0811	IP1 address	0 a 255																																
P0812	IP2 address	0 a 255																																
P0813	IP3 address	0 a 255																																
P0814	IP4 address	0 a 255																																
P0815	CIDR (subnet mask)	<table border="0"> <tr> <td>0 = Reserved</td> <td>16 = 255.255.0.0</td> </tr> <tr> <td>1 = 128.0.0.0</td> <td>17 = 255.255.128.0</td> </tr> <tr> <td>2 = 192.0.0.0</td> <td>18 = 255.255.192.0</td> </tr> <tr> <td>3 = 224.0.0.0</td> <td>19 = 255.255.224.0</td> </tr> <tr> <td>4 = 240.0.0.0</td> <td>20 = 255.255.240.0</td> </tr> <tr> <td>5 = 248.0.0.0</td> <td>21 = 255.255.248.0</td> </tr> <tr> <td>6 = 252.0.0.0</td> <td>22 = 255.255.252.0</td> </tr> <tr> <td>7 = 254.0.0.0</td> <td>23 = 255.255.254.0</td> </tr> <tr> <td>8 = 255.0.0.0</td> <td>24 = 255.255.255.0</td> </tr> <tr> <td>9 = 255.128.0.0</td> <td>25 = 255.255.255.128</td> </tr> <tr> <td>10 = 255.192.0.0</td> <td>26 = 255.255.255.192</td> </tr> <tr> <td>11 = 255.224.0.0</td> <td>27 = 255.255.255.224</td> </tr> <tr> <td>12 = 255.240.0.0</td> <td>28 = 255.255.255.240</td> </tr> <tr> <td>13 = 255.248.0.0</td> <td>29 = 255.255.255.248</td> </tr> <tr> <td>14 = 255.252.0.0</td> <td>30 = 255.255.255.252</td> </tr> <tr> <td>15 = 255.254.0.0</td> <td>31 = 255.255.255.254</td> </tr> </table>	0 = Reserved	16 = 255.255.0.0	1 = 128.0.0.0	17 = 255.255.128.0	2 = 192.0.0.0	18 = 255.255.192.0	3 = 224.0.0.0	19 = 255.255.224.0	4 = 240.0.0.0	20 = 255.255.240.0	5 = 248.0.0.0	21 = 255.255.248.0	6 = 252.0.0.0	22 = 255.255.252.0	7 = 254.0.0.0	23 = 255.255.254.0	8 = 255.0.0.0	24 = 255.255.255.0	9 = 255.128.0.0	25 = 255.255.255.128	10 = 255.192.0.0	26 = 255.255.255.192	11 = 255.224.0.0	27 = 255.255.255.224	12 = 255.240.0.0	28 = 255.255.255.240	13 = 255.248.0.0	29 = 255.255.255.248	14 = 255.252.0.0	30 = 255.255.255.252	15 = 255.254.0.0	31 = 255.255.255.254
0 = Reserved	16 = 255.255.0.0																																	
1 = 128.0.0.0	17 = 255.255.128.0																																	
2 = 192.0.0.0	18 = 255.255.192.0																																	
3 = 224.0.0.0	19 = 255.255.224.0																																	
4 = 240.0.0.0	20 = 255.255.240.0																																	
5 = 248.0.0.0	21 = 255.255.248.0																																	
6 = 252.0.0.0	22 = 255.255.252.0																																	
7 = 254.0.0.0	23 = 255.255.254.0																																	
8 = 255.0.0.0	24 = 255.255.255.0																																	
9 = 255.128.0.0	25 = 255.255.255.128																																	
10 = 255.192.0.0	26 = 255.255.255.192																																	
11 = 255.224.0.0	27 = 255.255.255.224																																	
12 = 255.240.0.0	28 = 255.255.255.240																																	
13 = 255.248.0.0	29 = 255.255.255.248																																	
14 = 255.252.0.0	30 = 255.255.255.252																																	
15 = 255.254.0.0	31 = 255.255.255.254																																	
P0816	Gateway 1	0 a 255																																
P0817	Gateway 2	0 a 255																																
P0818	Gateway 3	0 a 255																																
P0819	Gateway 4	0 a 255																																

5.5.3 POSSIBLE FORMS OF CONNECTIONS

Figure ?? illustrates the possible ways to connect the CFW500 to the Drive Scan.

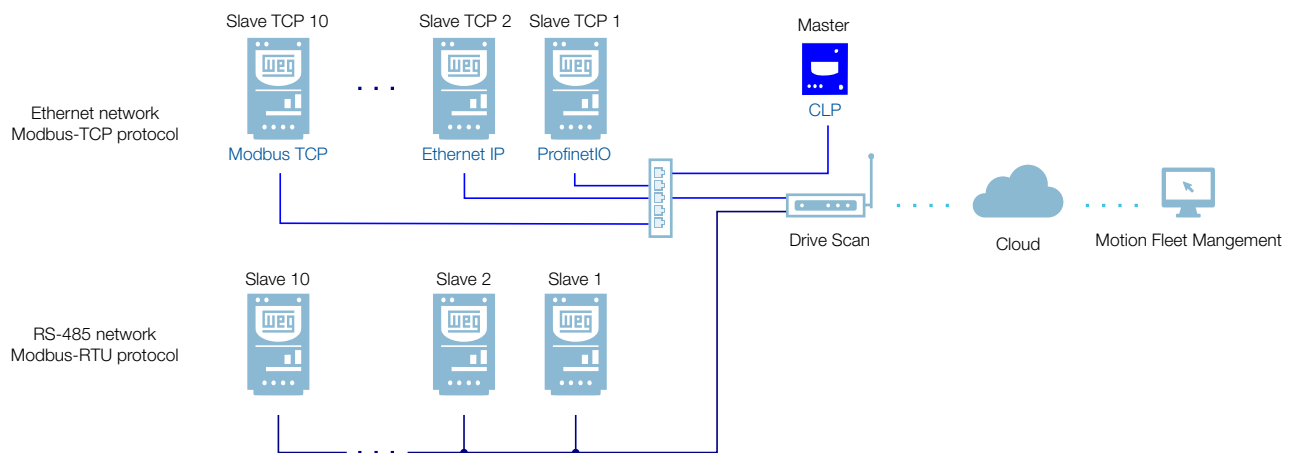
Figure 5.7: Possible connections to the CFW500

WARNING!

The Drive Scan can only be connected to the internet using the Ethernet port GbE0 if it does not have a proxy.

5.5.4 MONITORING

The Drive Scan continuously monitors the CFW500 parameters specified in [Section ?? ?? on page ??](#) . After a cycle of all these readings, as well as of the other assets connected to the Drive Scan, a new reading cycle starts automatically.

The parameters read are transformed into attributes, which can be:

- Only at initialization;
- Last value read;
- Average value;
- Minimum value;
- Maximum value.

5

Every 5 minutes, the Drive Scan publishes the attributes to the WEG Fleet Management platform. In case of an internet connection failure, the Drive Scan stores the data for up to 30 days in the internal memory, publishing it to the MFM when the connection is reestablished.

In case the CFW500 fails, the Drive Scan automatically publishes the parameters specified in [Section ?? ?? on page ??](#) asynchronously, that is, without waiting for the normal cyclical period of publication.

5.5.4.1 Attributes Cyclically Monitored by the CFW500

Parâmetro	Descrição	Atributo	Tipo de aquisição	Classe
P0202	Control type	controlType	Inicialização	identification
P0295	Inverter rated current	inverterRatedCurrent	Inicialização	
P0296	Inverter rated voltage	inverterRatedVoltage	Inicialização	
P0401	Motor rated current	motorRatedCurrent	Inicialização	
P0402	Motor rated speed	motorRatedSpeed	Inicialização	
P0400	Motor rated voltage	motorRatedVoltage	Inicialização	
P0023	Software version	softwareVersion	Inicialização	
P0297	Switching frequency	switchingFrequency	Inicialização	
P0001	Motor speed reference	motorSpeedReferenceAvg	Valor médio	status
P0680	Status word	statusWord	Último valor	
P0042	Enabled hours	enabledHours	Último valor	diagnostic
P0048	Present alarm	presentAlarm	Último valor	
P0049	Present fault	presentFault	Último valor	
P0004	DC link voltage	dcLinkVoltageAvg dcLinkVoltageMin dcLinkVoltageMax	Valor médio Valor mínimo Valor máximo	measurement
P0003	Motor current	motorCurrentAvg motorCurrentMin motorCurrentMax	Valor médio Valor mínimo Valor máximo	
P0005	Motor frequency	motorFrequencyAvg motorFrequencyMin motorFrequencyMax	Valor médio Valor mínimo Valor máximo	
P0037	Motor overload	motorOverloadAvg motorOverloadMin motorOverloadMax	Valor médio Valor mínimo Valor máximo	
P0002	Motor speed	motorSpeedAvg	Valor médio	
P0009	Motor torque	motorTorqueAvg motorTorqueMin motorTorqueMax	Valor médio Valor mínimo Valor máximo	
P0007	Motor voltage	motorVoltageAvg motorVoltageMin motorVoltageMax	Valor médio Valor mínimo Valor máximo	
P0010	Output power	outputPowerAvg outputPowerMin outputPowerMax	Valor médio Valor mínimo Valor máximo	
P0030	Module temperature	moduleTemperatureAvg	Valor médio	temperature
P0018	Analog input 1	analogInput1	Último valor	io
P0019	Analog input 2	analogInput2	Último valor	
P0014	Analog output 1	analogOutput1	Último valor	
P0015	Analog output 2	analogOutput2	Último valor	
P0012	Digital inputs	digitalInputs	Último valor	
P0013	Digital outputs	digitalOutputs	Último valor	

5.5.4.2 Attributes Monitored in Events by the CFW300

Parâmetro	Description	Attribute	Acquisition type	Class
P0090	Current at Last Fault	faultCurrent	Last value	Event
P0091	DC Link at Last Fault	faultCC	Last value	Event
P0092	Speed at Last Fault	faultVelocity	Last value	Event
P0093	Reference at Last Fault	faultReference	Last value	Event
P0094	Frequency at Last Fault	faultFrequency	Last value	Event
P0095	Motor Voltage at Last Fault	faultVoltageMotor	Last value	Event
P0096	Digital Input States at Last Fault Falha	faultDI	Last value	Event

5.6 CFW700 FREQUENCY INVERTER

5.6.1 RS-485

To connect the CFW700 to the Drive Scan via the RS-485 communication interface, using the Modbus-RTU protocol, the RS-485 interface on the inverter can be used, respecting the minimum allowed version of the CFW700 firmware. In [Table ??](#) the interface pins and signals are listed.

WEG’s download center, which can be accessed via the link www.weg.net, is a channel that allows the user can find a wide range of documents on WEG equipment and accessories, as well as installation guides. For additional information about the CFW700’s RS-485 communication, search for “CFW700 modbus rtu” and access the manual “CFW700 - Modbus RTU”.

It is very important to activate the terminating resistors at the ends of the RS-485 network.

Table 5.16: CFW700 RS-485 interface pins and signals

Paramaters	Pin	Signal
Table ??	10	A (-)
	9	B (+)
	8	GND

Table 5.17: Parâmetros relacionados à interface RS-485

Parameter	Description	Values range
P0308	Serial address	1 a 247
P0310	Serial baud rate	0 = 9600 bps 1 = 19200 bps 2 = 38400 bps 3 = 57600 bps
P0311	Serial interface byte configuration	0 = 8 bits, no parity, 1 stop bit 1 = 8 bits, even parity, 1 stop bit 2 = 8 bits, odd parity, 1 stop bit 3 = 8 bits, no parity, 2 stop bits 4 = 8 bits, even parity, 2 stop bits 5 = 8 bits, odd parity, 2 stop bits
P0312	Serial protocol	2 = Modbus RTU
P0313	Action for communication error	0 = Inactive 1 = Ramp stop 2 = General disable 3 = Go to LOCAL 4 = LOCAL holds enabled 5 = Fault cause
P0314	Serial Watchdog	0,0 a 999,0 s
P0316	Serial interface status	0 = Inactive 1 = Active 2 = Watchdog error

5.6.2 POSSIBLE FORMS OF CONNECTIONS

[Figure ??](#) illustrates the possible ways to connect the CFW700 to the Drive Scan.

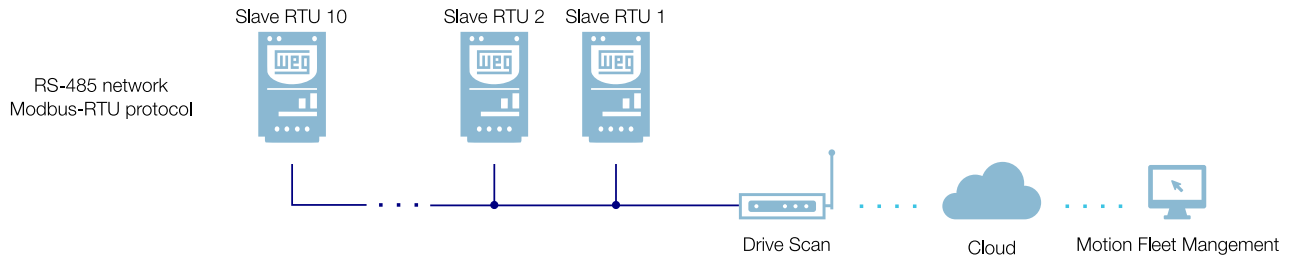

Figure 5.8: Possible connections with the CFW700



WARNING!

The Drive Scan can only be connected to the internet using the Ethernet port GbE0 if the network does not have a proxy.

5.6.3 MONITORING

The Drive Scan continuously monitors the CFW700 parameters specified in [Section ?? ?? on page ??](#). After a cycle of all those readings, as well as of the other assets connected to the Drive Scan, a new reading cycle starts automatically.

The parameters read are transformed into attributes, which can be:

- Only at initialization;
- Last value read;
- Average value;
- Minimum value;
- Maximum value.

Every 5 minutes, the Drive Scan publishes the attributes to the WEG Fleet Management platform. In case of an internet connection failure, the Drive Scan stores the data for up to 30 days in the internal memory, publishing it to the MFM when the connection is reestablished.

In case the CFW700 fails, the Drive Scan automatically publishes the parameters specified in [Section ?? ?? on page ??](#) asynchronously, that is, without waiting for the normal cyclical period of publication.



5.6.3.1 Attributes Cyclically Monitored by the CFW700

Parameter	Description	Attribute	Acquisition type	Class	
P0202	Control type	controlType	Initialization	identification	
P0295	Inverter rated current	inverterRatedCurrent	Initialization		
P0296	Inverter rated voltage	inverterRatedVoltage	Initialization		
P0401	Motor rated current	motorRatedCurrent	Initialization		
P0402	Motor rated speed	motorRatedSpeed	Initialization		
P0400	Motor rated voltage	motorRatedVoltage	Initialization		
P0023	Software version	softwareVersion	Initialization		
P0297	Switching frequency	switchingFrequency	Initialization		
P0001	Motor speed reference	motorSpeedReferenceAvg	Average	status	
P0680	Status word	statusWord	Last value		
P0043	Enabled hours	enabledHours	Last value	diagnostic	
P0042	Energized hours	energizedHours	Last value		
P0048	Present alarm	presentAlarm	Last value		
P0049	Present fault	presentFault	Last value		
P0004	DC link voltage	dcLinkVoltageAvg dcLinkVoltageMin dcLinkVoltageMax	Average Minimum value Maximum value	measurement	
P0044	Energy counter	energyCounterAvg	Average		
P0036	Fan speed	fanSpeed	Last value		
P0003	Motor current	motorCurrentAvg motorCurrentMin motorCurrentMax	Average Minimum value Maximum value		
P0005	Motor frequency	motorFrequencyAvg motorFrequencyMin motorFrequencyMax	Average Minimum value Maximum value		
P0037	Motor overload	motorOverloadAvg motorOverloadMin motorOverloadMax	Average Minimum value Maximum value		
P0002	Motor speed	motorSpeedAvg	Average		
P0009	Motor torque	motorTorqueAvg motorTorqueMin motorTorqueMax	Average Minimum value Maximum value		
P0007	Motor voltage	motorVoltageAvg motorVoltageMin motorVoltageMax	Average Minimum value Maximum value		
P0010	Output power	outputPowerAvg outputPowerMin outputPowerMax	Average Minimum value Maximum value		
P0011	Output power factor	outputPowerFactor	Last value		
P0034	Air temperature	airTemperatureAvg	Average		temperature
P0035	Control temperature	controlTemperatureAvg	Average		
P0030	Phase U temperature	phaseUTemperatureAvg	Average		
P0031	Phase V temperature	phaseVTemperatureAvg	Average		
P0032	Phase W temperature	phaseWTemperatureAvg	Average		
P0033	Rectifier temperature	rectifierTemperatureAvg	Average		
P0018	Analog input 1	analogInput1	Last value	io	
P0019	Analog input 2	analogInput2	Last value		
P0020	Analog input 3	analogInput3	Last value		
P0021	Analog input 4	analogInput4	Last value		
P0014	Analog output 1	analogOutput1	Last value		
P0015	Analog output 2	analogOutput2	Last value		
P0016	Analog output 3	analogOutput3	Last value		
P0017	Analog output 4	analogOutput4	Last value		
P0012	Digital inputs	digitalInputs	Last value		
P0013	Digital outputs	digitalOutputs	Last value		

5.6.3.2 Attributes Monitored in Events by the CFW700

Parâmetro	Description	Attribute	Acquisition type	Class
P0090	Current at Last Fault	faultCurrent	Last value	Event
P0091	DC Link at Last Fault	faultCC	Last value	Event
P0092	Speed at Last Fault	faultVelocity	Last value	Event
P0093	Reference at Last Fault	faultReference	Last value	Event
P0094	Frequency at Last Fault	faultFrequency	Last value	Event
P0095	Motor Voltage at Last Fault	faultVoltageMotor	Last value	Event
P0096	Digital Input States at Last Fault Falha	faultDI	Last value	Event

5.7 SSW900 SOFT-STARTER

5.7.1 RS-485

To connect the SSW900 to the Drive Scan via the RS-485 communication interface using the Modbus-RTU protocol, it is necessary to install on the Soft-Starter the accessory CRS485-W listed in Table ??, which can be used with firmware version 1.0 and above of the SSW900.

Refer to the SSW900 Modbus-RTU Communication guide, which can be obtained from the download center at www.weg.net, for additional information.

Table 5.18: RS-485 hardware accessory of the SSW900 compatible with the Modbus RTU protocol

Accessory	WEG item	Parameters	Pin	Signal
CRS485-W 	12966043	Table ??	1	B (+)
			2	A (-)
			3	GND
			4	Shield

Table 5.19: Parameters related to the RS-485 communication accessories

Parameter	Net ID	Description	Values range
C8.2.1	730	Serial protocol	2 = Modbus RTU
C8.2.2	731	Serial address	1 a 247
C8.2.3	732	Serial baud rate	0 = 9600 bps 1 = 19200 bps 2 = 38400 bps 3 = 57600 bps
C8.2.4	733	Serial interface byte configuration	0 = 8 bits, no parity, 1 stop bit 1 = 8 bits, even parity, 1 stop bit 2 = 8 bits, odd parity, 1 stop bit 3 = 8 bits, no parity, 2 stop bits 4 = 8 bits, even parity, 2 stop bits 5 = 8 bits, odd parity, 2 stop bits
C8.2.5.1	740	Timeout mode	0 = Inactive 1 = F128 fault 2 = A128 alarm
C8.2.5.2	741	Timeout error action	0 = Only indicates 1 = Ramp stop 2 = General disable 3 = Go to LOC 4 = Go to REM
C8.2.5.3	734	Timeout	0,0 a 999,0s

5.7.2 ETHERNET

To connect to the Drive Scan via Ethernet GbE1 communication interface using the Modbus TCP protocol, it is necessary to install on the SSW900 the accessory CMB-TCP-N listed in [Table ??](#).

Table 5.20: Ethernet hardware accessory of the SSW900 compatible with the Modbus TCP protocol

Accessory	WEG item	Modbus TCP clients	SSW900 firmware	Parameters
CMB-TCP-N 	12966038	2	≥ V1.00	Table ??

Table 5.21: Parameters related to the CMB-TCP-N

Parameter	Net ID	Description	Values range																																
C8.3.4	760	IP address configuration	0 = Parameters 1 = DHCP																																
C8.3.5	762	IP address	0.0.0.0 a 255.255.255.255																																
C8.3.6	761	CIDR (subnet mask)	<table border="0"> <tr> <td>0 = Reserved</td> <td>16 = 255.255.0.0</td> </tr> <tr> <td>1 = 128.0.0.0</td> <td>17 = 255.255.128.0</td> </tr> <tr> <td>2 = 192.0.0.0</td> <td>18 = 255.255.192.0</td> </tr> <tr> <td>3 = 224.0.0.0</td> <td>19 = 255.255.224.0</td> </tr> <tr> <td>4 = 240.0.0.0</td> <td>20 = 255.255.240.0</td> </tr> <tr> <td>5 = 248.0.0.0</td> <td>21 = 255.255.248.0</td> </tr> <tr> <td>6 = 252.0.0.0</td> <td>22 = 255.255.252.0</td> </tr> <tr> <td>7 = 254.0.0.0</td> <td>23 = 255.255.254.0</td> </tr> <tr> <td>8 = 255.0.0.0</td> <td>24 = 255.255.255.0</td> </tr> <tr> <td>9 = 255.128.0.0</td> <td>25 = 255.255.255.128</td> </tr> <tr> <td>10 = 255.192.0.0</td> <td>26 = 255.255.255.192</td> </tr> <tr> <td>11 = 255.224.0.0</td> <td>27 = 255.255.255.224</td> </tr> <tr> <td>12 = 255.240.0.0</td> <td>28 = 255.255.255.240</td> </tr> <tr> <td>13 = 255.248.0.0</td> <td>29 = 255.255.255.248</td> </tr> <tr> <td>14 = 255.252.0.0</td> <td>30 = 255.255.255.252</td> </tr> <tr> <td>15 = 255.254.0.0</td> <td>31 = 255.255.255.254</td> </tr> </table>	0 = Reserved	16 = 255.255.0.0	1 = 128.0.0.0	17 = 255.255.128.0	2 = 192.0.0.0	18 = 255.255.192.0	3 = 224.0.0.0	19 = 255.255.224.0	4 = 240.0.0.0	20 = 255.255.240.0	5 = 248.0.0.0	21 = 255.255.248.0	6 = 252.0.0.0	22 = 255.255.252.0	7 = 254.0.0.0	23 = 255.255.254.0	8 = 255.0.0.0	24 = 255.255.255.0	9 = 255.128.0.0	25 = 255.255.255.128	10 = 255.192.0.0	26 = 255.255.255.192	11 = 255.224.0.0	27 = 255.255.255.224	12 = 255.240.0.0	28 = 255.255.255.240	13 = 255.248.0.0	29 = 255.255.255.248	14 = 255.252.0.0	30 = 255.255.255.252	15 = 255.254.0.0	31 = 255.255.255.254
0 = Reserved	16 = 255.255.0.0																																		
1 = 128.0.0.0	17 = 255.255.128.0																																		
2 = 192.0.0.0	18 = 255.255.192.0																																		
3 = 224.0.0.0	19 = 255.255.224.0																																		
4 = 240.0.0.0	20 = 255.255.240.0																																		
5 = 248.0.0.0	21 = 255.255.248.0																																		
6 = 252.0.0.0	22 = 255.255.252.0																																		
7 = 254.0.0.0	23 = 255.255.254.0																																		
8 = 255.0.0.0	24 = 255.255.255.0																																		
9 = 255.128.0.0	25 = 255.255.255.128																																		
10 = 255.192.0.0	26 = 255.255.255.192																																		
11 = 255.224.0.0	27 = 255.255.255.224																																		
12 = 255.240.0.0	28 = 255.255.255.240																																		
13 = 255.248.0.0	29 = 255.255.255.248																																		
14 = 255.252.0.0	30 = 255.255.255.252																																		
15 = 255.254.0.0	31 = 255.255.255.254																																		
C8.3.7	766	Gateway	0.0.0.0 a 255.255.255.255																																
C8.3.9.1	771	Timeout mode	0 = Inactive 1 = F131 fault 2 = A131 alarm																																
C8.3.9.2	772	Timeout error action	0 = Only indicates 1 = Ramp stop 2 = General disable 3 = Go to LOC 4 = Go to REM																																
C8.3.9.3	759	Modbus TCP timeout	0 a 999,9s																																

5.7.3 POSSIBLE FORMS OF CONNECTIONS

[Figure ??](#) illustrates the possible ways to connect the SSW900 to the Drive Scan.

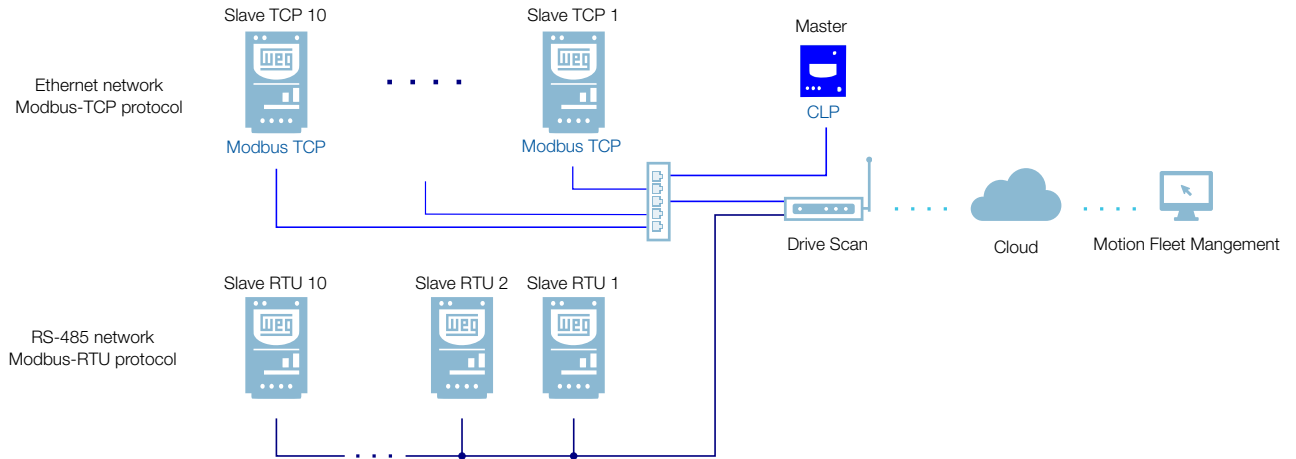

Figure 5.9: Possible connections to the SSW900



WARNING!

The Drive Scan can only be connected to the internet using the Ethernet port GbE0 if it does not have a proxy.

5.7.4 MONITORING

The Drive Scan continuously monitors the SSW900 parameters specified in [Section ?? ?? on page ??](#) . After a cycle of all these readings, as well as of the other assets connected to the Drive Scan, a new reading cycle starts automatically.

The parameters read are transformed into attributes, which can be:

- Only at initialization;
- Last value read;
- Average value;
- Minimum value;
- Maximum value.

Every 5 minutes, the Drive Scan publishes the attributes to the WEG Fleet Management platform. In case of an internet connection failure, the Drive Scan stores the data for up to 30 days in the internal memory, publishing it to the MFM when the connection is reestablished.



5.7.4.1 5.6.4.1 Attributes Cyclically Monitored by the SSW900

Parameter	Net Id	Description	Attribute	Acquisition type	Class
S3.2.1	328	Software version (Package)	softwareVersion	Last value	identification
S3.3.2	4	Line voltage	lineVoltage	Last value	identification
S3.5.1	335	Slot 1 accessory	slot1Accessory	Last value	identification
S3.5.2	336	Slot 2 accessory	slot2Accessory	Last value	identification
C1.1	202	Control type	controlType	Last value	identification
D1.3	102	Max start time	maxStartTime	Last value	identification
C9.1.1	295	Rated current	nominalCurrent	Last value	identification
S1.1.1	26	R phase current	phaseCurrentR	Last value	measurement
S1.1.2	28	S phase current	phaseCurrentS	Last value	measurement
S1.1.3	30	T phase current	phaseCurrentT	Last value	measurement
S1.1.4	24	Average current	motorCurrent	Average value	measurement
S1.2.1	33	R-S line voltage	lineVoltageRs	Last value	measurement
S1.2.2	34	S-T line voltage	lineVoltageSt	Last value	measurement
S1.2.3	35	T-R line voltage	lineVoltageTr	Last value	measurement
S1.2.4	4	Average line voltage	lineVoltage	Last value	measurement
S1.3.1	7	Average output voltage	motorVoltage	Average value	measurement
S1.5.1	10	Active power	outputPower	Average value	measurement
S1.5.2	12	Apparent power	apparentPower	Average value	measurement
S1.5.3	14	Reactive power	reactivePower	Average value	measurement
S1.5.4	8	Power factor	powerFactor	Average value	measurement
S1.7	9	Motor torque	motorTorque	Average value	measurement
S1.8.1	71	Control voltage	controlVoltage	Last value	measurement
S2.1.1	677	DI1 to DI6 status	digitalInputs	Last value	io
S2.1.2	678	DO1 to DO3 status	digitalOutputs	Last value	io
S2.2.1	673	AO status	analogOutput	Last value	io
S3.1.1	680	Status word	statusWord	Last value	status
S3.1.2	232	Active command source	activeCommandSource	Last value	identification
S4.1.1	60	SRC temperature	scrTemperature	Average value	temperature
S4.2.1	50	Therma class state	thermalState	Average value	status
D2.1.1	91	Alarme code	presentAlarm	Last value	diagnostic
D1.1.1	90	Fault code	presentFault	Last value	diagnostic
D4.1.1	69	Max start current	maxStartCurrent	Last value	measurement
D4.6.1	52	kWh counter	energyCounter	Last value	measurement
D4.7	59	Total starts number	totalStartsNumber	Last value	measurement
D6.1	42	Energized hours counter	energizedHours	Last value	measurement
D6.2	44	Enabled hours counter	enabledHours	Last value	measurement
D6.3	46	Fan enabled time	fanHours	Last value	measurement

5.8 SRW01 SMART RELAY

5.8.1 ETHERNET

The following SRW01 Ethernet models support communication with the Drive Scan:

- SRW01-ETH-EIP: EtherNet/IP protocol,
- SRW01-ETH-MBTCP: Modbus TCP protocol,
- SRW01-ETH-PNIO: PROFINET IO protocol.

The Ethernet models of the SRW01 allow communication with the Drive Scan via Ethernet using the Modbus-TCP protocol, and it is not necessary to install an additional communication module. The SRW01 Ethernet has two Ethernet ports, Port 1 and Port 2, whose communication settings can be programmed through the parameters listed in [Table ??](#). It is important to point out that communication can only be performed with firmware v2.00 and above of the SRW01.

Table 5.22: Parameters related to the SRW01 Ethernet Modbus protocol

Parameter	Description	Values range																																
P0751	Ethernet communication status	0 = Setup 1 = Init 2 = Wait Comm 3 = Idle 4 = Data Active 5 = Error 6 = Reserved 7 = Exception 8 = Access Error																																
P0753	Ethernet baud rate	0 = Auto 1 = 10 Mbps, half duplex 2 = 10 Mbps, full duplex 3 = 100 Mbps, half duplex 4 = 100 Mbps, full duplex																																
P760	IP address configuration	0 = Parameters 1 = DHCP 2 = DCP																																
P761	IP 1 address	0... 255																																
P762	IP 2 address	0... 255																																
P763	IP 3 address	0... 255																																
P764	IP 4 address	0... 255																																
P765	CIDR (subnet mask)	<table style="width: 100%; border: none;"> <tr> <td>0 = Reserved</td> <td>16 = 255.255.0.0</td> </tr> <tr> <td>1 = 128.0.0.0</td> <td>17 = 255.255.128.0</td> </tr> <tr> <td>2 = 192.0.0.0</td> <td>18 = 255.255.192.0</td> </tr> <tr> <td>3 = 224.0.0.0</td> <td>19 = 255.255.224.0</td> </tr> <tr> <td>4 = 240.0.0.0</td> <td>20 = 255.255.240.0</td> </tr> <tr> <td>5 = 248.0.0.0</td> <td>21 = 255.255.248.0</td> </tr> <tr> <td>6 = 252.0.0.0</td> <td>22 = 255.255.252.0</td> </tr> <tr> <td>7 = 254.0.0.0</td> <td>23 = 255.255.254.0</td> </tr> <tr> <td>8 = 255.0.0.0</td> <td>24 = 255.255.255.0</td> </tr> <tr> <td>9 = 255.128.0.0</td> <td>25 = 255.255.255.128</td> </tr> <tr> <td>10 = 255.192.0.0</td> <td>26 = 255.255.255.192</td> </tr> <tr> <td>11 = 255.224.0.0</td> <td>27 = 255.255.255.224</td> </tr> <tr> <td>12 = 255.240.0.0</td> <td>28 = 255.255.255.240</td> </tr> <tr> <td>13 = 255.248.0.0</td> <td>29 = 255.255.255.248</td> </tr> <tr> <td>14 = 255.252.0.0</td> <td>30 = 255.255.255.252</td> </tr> <tr> <td>15 = 255.254.0.0</td> <td>31 = 255.255.255.254</td> </tr> </table>	0 = Reserved	16 = 255.255.0.0	1 = 128.0.0.0	17 = 255.255.128.0	2 = 192.0.0.0	18 = 255.255.192.0	3 = 224.0.0.0	19 = 255.255.224.0	4 = 240.0.0.0	20 = 255.255.240.0	5 = 248.0.0.0	21 = 255.255.248.0	6 = 252.0.0.0	22 = 255.255.252.0	7 = 254.0.0.0	23 = 255.255.254.0	8 = 255.0.0.0	24 = 255.255.255.0	9 = 255.128.0.0	25 = 255.255.255.128	10 = 255.192.0.0	26 = 255.255.255.192	11 = 255.224.0.0	27 = 255.255.255.224	12 = 255.240.0.0	28 = 255.255.255.240	13 = 255.248.0.0	29 = 255.255.255.248	14 = 255.252.0.0	30 = 255.255.255.252	15 = 255.254.0.0	31 = 255.255.255.254
0 = Reserved	16 = 255.255.0.0																																	
1 = 128.0.0.0	17 = 255.255.128.0																																	
2 = 192.0.0.0	18 = 255.255.192.0																																	
3 = 224.0.0.0	19 = 255.255.224.0																																	
4 = 240.0.0.0	20 = 255.255.240.0																																	
5 = 248.0.0.0	21 = 255.255.248.0																																	
6 = 252.0.0.0	22 = 255.255.252.0																																	
7 = 254.0.0.0	23 = 255.255.254.0																																	
8 = 255.0.0.0	24 = 255.255.255.0																																	
9 = 255.128.0.0	25 = 255.255.255.128																																	
10 = 255.192.0.0	26 = 255.255.255.192																																	
11 = 255.224.0.0	27 = 255.255.255.224																																	
12 = 255.240.0.0	28 = 255.255.255.240																																	
13 = 255.248.0.0	29 = 255.255.255.248																																	
14 = 255.252.0.0	30 = 255.255.255.252																																	
15 = 255.254.0.0	31 = 255.255.255.254																																	

Table 5.22: Parameters related to the SRW01 Ethernet Modbus protocol

Parameter	Description	Values range
P766	Gateway 1	0... 255
P767	Gateway 2	0... 255
P768	Gateway 3	0... 255
P769	Gateway 4	0... 255
P756	Modbus TCP timeout	0 a 999,9s

5.8.2 POSSIBLE FORMS OF CONNECTIONS

5

Figure ?? illustrates the possible ways to connect the SRW01 to the Drive Scan.

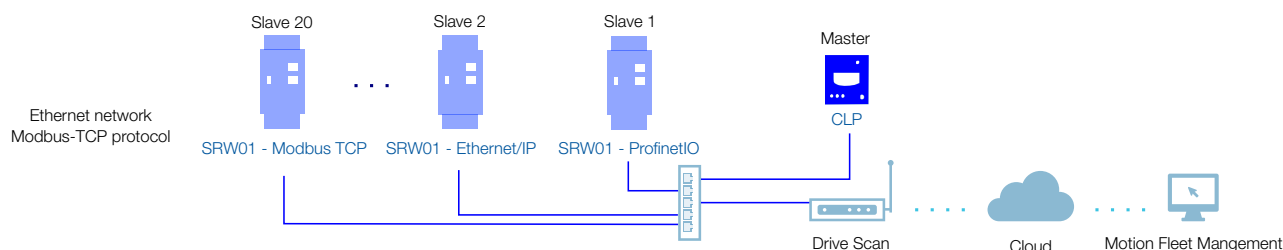

Figure 5.10: Possible connections to the SRW01

WARNING!

The Drive Scan can only be connected to the internet using the Ethernet port GbE0 if it does not have a proxy.

5.8.3 MONITORING

The Drive Scan continuously monitors the SRW01 parameters specified in Section ?? ?? on page ?? . After a cycle of all these readings, as well as of the other assets connected to the Drive Scan, a new reading cycle starts automatically.

The parameters read are transformed into attributes, which can be:

- Only at initialization;
- Last value read;
- Average value;
- Minimum value;
- Maximum value.

Every 5 minutes, the Drive Scan publishes the attributes to the WEG Motion Fleet Management platform. In case of an internet connection failure, the Drive Scan stores the data for up to 30 days in the internal memory, publishing it to the MFM when the connection is reestablished.

5.8.3.1 Attributes Cyclically Monitored by the SRW01

Parameter	Description	Atributo	Acquisition type	Class
P002	Current (%)	ratedCurrent	Last value	measurement
P003	True RMS current	motorCurrent	Valor médio	measurement
P004	True RMS line voltage	lineVoltage	Last value	measurement
P006	Relay status	status	Last value	measurement
P008	Power factor	powerFactor	Valor médio	measurement
P009	Motor reactive power	reactivePower	Last value	measurement
P010	Motor active power	outputPower	Valor médio	measurement
P011	Motor apparent power	apparentPower	Last value	measurement
P014	Last fault	lastFault	Last value	diagnostic
P016	Current error	currentError	Last value	diagnostic
P020	PTC value (ohms)	ptcValue	Last value	measurement
P030	R phase true RMS current	phaseCurrentR	Last value	measurement
P031	S phase true RMS current	phaseCurrentS	Last value	measurement
P032	T phase true RMS current	phaseCurrentT	Last value	measurement
P033	L1-L2 line voltage	lineVoltageRs	Last value	measurement
P034	L2-L3 line voltage	lineVoltageSt	Last value	measurement
P035	L3-L1 line voltage	lineVoltageTr	Last value	measurement
P036	Earth leakage current (%)	earthLeakage	Last value	measurement
P037	True RMS earth leakage current	eathLeakageCurrent	Last value	measurement
P042	Energized hours	energizedHours	Last value	diagnostic
P043	Motor on hours	motorOnHours	Last value	diagnostic
P044	kWh counter	energyCounter	Last value	measurement
P050	Thermal protection	thermalProtection	Last value	measurement
P051	Current imbalance level	currentUnbalance	Last value	measurement
P052	Earth fault imbalance	earthFault	Last value	measurement
P053	Voltage imbalance level	voltageUnbalance	Last value	measurement
P060	Total starts number	startsNumber	Last value	measurement
P061	Overload trips	overloadTrips	Last value	measurement
P062	Current imbalance trips	currentUnbalanceTrips	Last value	measurement
P063	Earth fault trips	earthFaultTrips	Last value	measurement
P064	Phase fault trips (current)	currentPhaseFaultTrips	Last value	measurement
P065	Overcurrent trips	overcurrentTrips	Last value	measurement
P066	Undercurrent trips	undercurrentTrips	Last value	measurement
P067	Phase out of range trips	outOfPhaseTrips	Last value	measurement
P068	PTC trips	ptcTrips	Last value	measurement
P069	Earth leakage trips	earthLeakageTrips	Last value	measurement
P070	External fault trips	externalFaultTrips	Last value	measurement
P071 a P073	Trip 1 to 3 status	tripStatus1 a tripStatus3	Last value	status
P075 a P077	Alarm 1 to 3 status	alarmStatus1	Last value	status
P082	Total trips	totalTrips	Last value	measurement
P100	Voltage imbalance trips	voltageUnbalanceTrips	Last value	measurement
P101	Out of phase trips	outOfPhaseTrips	Last value	measurement
P102	Overvoltage trips	overvoltageTrips	Last value	measurement
P103	Undervoltage trips	undervoltageTrips	Last value	measurement
P104	Underpower trips	underpowerTrips	Last value	measurement
P105	Overpower trips	overpowerTrips	Last value	measurement
P106	Power underfactor trips	powerUnderfactorTrips	Last value	measurement
P107	Power overfactor trips	powerOverfactorTrips	Last value	measurement
P110 a P111	Trip 4 to 5 status	tripStatus4 a tripStatus5	Last value	status
P115 a P116	Alarm 4 to 5 status	alarmStatus1 a alarmStatus5	Last value	status

5.9 MODULAR CFW11 FREQUENCY INVERTER

5.9.1 RS-485

To connect the Modular CFW11 (CFW11M) to the Drive Scan via the RS-485 communication interface, using the Modbus-RTU protocol, it is necessary to install one of the following accessories on the CFW11M listed in [Table ??](#). The minimum Modbus RTU compatible version is v3.14 for the G1 model and v1.1 for the G2 model.

WEG’s download center, which can be accessed via the link www.weg.net, is a channel that allows the user can find a wide range of documents on WEG equipment and accessories, as well as installation guides. For additional information about the CFW11M’s RS-485 communication, access the manual “CFW11 - CFW11 RS-232/RS-485 Serial Communication Manual”. To obtain manuals on the PLC11-01 and PLC11-02 configuration and installation, search for the keyword “PLC11” in the download center.

It is very important to activate the terminating resistors at the ends of the RS-485 network.

Table 5.23: CFW11M RS-485 media accessories compatible with Modbus RTU protocol





Accessory	WEG Item	CFW11M model	Parameters	Pin	Signal
RS485-01 	11008102	G1 e G2	Table ??	1	Negative RxD/TxD
CAN/RS485-01 	10051960			2	RxD/TxD positivo
PLC11-01 	11008911	G2	Table ??	XC31:8	Negative RxD/TxD
PLC11-02	11094251			XC31:9	Positive RxD/TxD
RS-485-05 	11008161	G1 e G2	Table ??	1	+5V
				5	GND
				8	RxD/TxD
				9	RxD/TxD (inverted)

Table 5.24: Parameters related to the RS485-01, CAN/RS485-01 and RS485-05 accessories

Parameter	Description	Values range
P0308	Serial address	1 a 247
P0310	Serial baud rate	0 = 9600 bps 1 = 19200 bps 2 = 38400 bps 3 = 57600 bps
P0311	Serial interface byte configuration	0 = 8 bits, no parity, 1 stop bit 1 = 8 bits, even parity, 1 stop bit 2 = 8 bits, odd parity, 1 stop bit 3 = 8 bits, no parity, 2 stop bits 4 = 8 bits, even parity, 2 stop bits 5 = 8 bits, odd parity, 2 stop bits
P0312	Serial protocol	2 = Modbus RTU
P0313	Action for communication error	0 = Inactive 1 = Ramp stop 2 = General disable 3 = Go to LOCAL 4 = LOCAL holds enabled 5 = Fault cause
P0314	Serial Watchdog	0,0 a 999,0 s

Table 5.24: Parameters related to the RS485-01, CAN/RS485-01 and RS485-05 accessories

Parameter	Description	Values range
P0316	Serial interface status	0 = Inactive 1 = Active 2 = Watchdog error

Table 5.25: Parâmetros relacionados aos acessórios PLC11-01 e PLC11-02

Parameter	Description	Values range
P1280	Serial protocol	1 = Modbus RTU (Slave)
P1281	Serial address	1 a 247
P1282	Serial baud rate	0 = 1200 bps 1 = 2400 bps 2 = 4800 bps 3 = 9600 bps 4 = 19200 bps 5 = 38400 bps
P1283	Serial communication configuration	0 = 8 bits, no parity, 1 stop bit 1 = 8 bits, even parity, 1 stop bit 2 = 8 bits, odd parity, 1 stop bit 3 = 8 bits, no parity, 2 stop bits 4 = 8 bits, even parity, 2 stop bits 5 = 8 bits, odd parity, 2 stop bits
P1284	Serial Watchdog	0,0 a 999,0 s

Figure ?? illustrates an RS-485 network among the CFW11 inverters, using all communication modules.

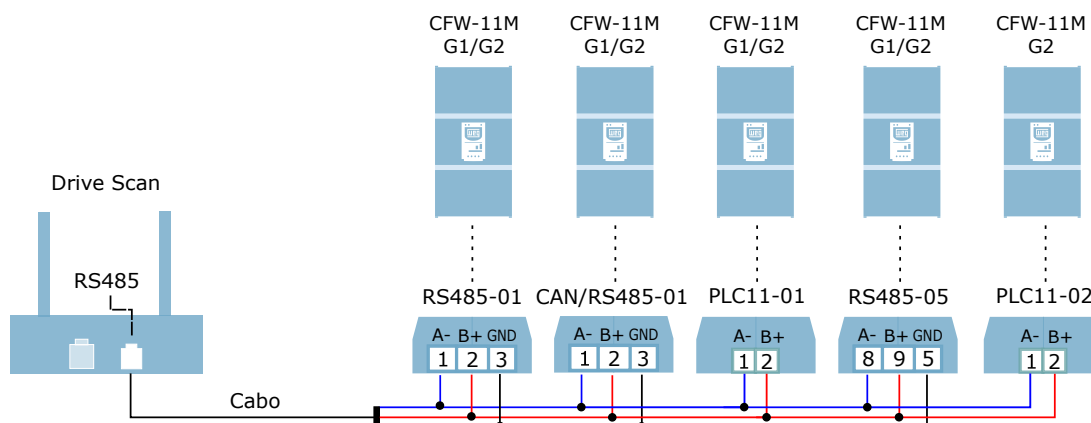
Figure 5.11: RS-485 network among several CFW11M and one Drive Scan

Note that the RS-485 signals (positive, negative and ground) of each inverter must share the same point or node. For example, the negative signals (A-) of inverters 1, 2, 3 and 4 must be connected to the same node. The same must be true for the positive (B+) and GND (if any) signals. It is important to remember that inverters in an RS-485 network must have different serial addresses.

5.9.2 ETHERNET

To connect to the Drive Scan via Ethernet GbE1 communication interface using the Modbus TCP protocol, it is necessary to install on the CFW11 one of the accessories listed in Table 5.7. It is also important to observe the following settings in the table:

- The maximum number of clients connected simultaneously to the accessory;
- The minimum compatible version of Drive Scan with the CFW11M G1 firmware is v6.0. For the G2 model the minimum version is v1.0.

For additional information, see the document “Anybus-CC Communication Modules” of the CFW11, which can be found in the download center at the website www.weg.net by searching for the keyword “anybus-cc”.

Table 5.26: Ethernet hardware accessories of the CFW11 compatible with the Modbus TCP protocol

Accessory	WEG Item	Modbus TCP clients	Modelo CFW11M Model	Parameters
ETHERNETIP-05 (1 or 2 ports)	10933688 (1P)	Up to 2	G1	Table 5.8
	12272760 (2P)			
MODBUSTCP-05 (1 or 2 ports)	11550476 (1P)	Up to 4	G2	
	14033951 (2P)			

Table 5.27: Parameters related to the MODBUSTCP-05 and ETHERNETIP-05 accessories

Parameter	Description	Values range
P0723	Anybus identification	0 = Inactive 10 = RS485 19 = EtherNet/IP 21 = Modbus TCP 23 = PROFINET IO Other = Not compatible with Drive Scan
P0724	Anybus communication status	0 = Inactive 1 = Not supported 2 = Access error 3 = Offline 4 = Online
P0725	Anybus address	0 a 255
P0840	Anybus status	0 = Setup 1 = Init 2 = Wait Comm 3 = Idle 4 = Data Active 5 = Error 6 = Reserved 7 = Exception 8 = Access Error
P0841	Ethernet baud rate	0 = Auto 1 = 10 Mbps, half duplex 2 = 10 Mbps, full duplex 3 = 100 Mbps, half duplex 4 = 100 Mbps, full duplex
P0842	Modbus TCP timeout	0 a 655 s
P0843	IP address configuration	0 = Parameters 1 = DHCP 2 = DCP 3 = IPconfig
P0844	IP1 address	0 a 255
P0846	IP2 address	0 a 255
P0847	IP3 address	0 a 255
P0848	IP4 address	0 a 255

Table 5.27: Parameters related to the MODBUSTCP-05 and ETHERNETIP-05 accessories

Parameter	Description	Values range																																
P0848	CIDR (subnet mask)	<table border="0"> <tr> <td>0 = Reserved</td> <td>16 = 255.255.0.0</td> </tr> <tr> <td>1 = 128.0.0.0</td> <td>17 = 255.255.128.0</td> </tr> <tr> <td>2 = 192.0.0.0</td> <td>18 = 255.255.192.0</td> </tr> <tr> <td>3 = 224.0.0.0</td> <td>19 = 255.255.224.0</td> </tr> <tr> <td>4 = 240.0.0.0</td> <td>20 = 255.255.240.0</td> </tr> <tr> <td>5 = 248.0.0.0</td> <td>21 = 255.255.248.0</td> </tr> <tr> <td>6 = 252.0.0.0</td> <td>22 = 255.255.252.0</td> </tr> <tr> <td>7 = 254.0.0.0</td> <td>23 = 255.255.254.0</td> </tr> <tr> <td>8 = 255.0.0.0</td> <td>24 = 255.255.255.0</td> </tr> <tr> <td>9 = 255.128.0.0</td> <td>25 = 255.255.255.128</td> </tr> <tr> <td>10 = 255.192.0.0</td> <td>26 = 255.255.255.192</td> </tr> <tr> <td>11 = 255.224.0.0</td> <td>27 = 255.255.255.224</td> </tr> <tr> <td>12 = 255.240.0.0</td> <td>28 = 255.255.255.240</td> </tr> <tr> <td>13 = 255.248.0.0</td> <td>29 = 255.255.255.248</td> </tr> <tr> <td>14 = 255.252.0.0</td> <td>30 = 255.255.255.252</td> </tr> <tr> <td>15 = 255.254.0.0</td> <td>31 = 255.255.255.254</td> </tr> </table>	0 = Reserved	16 = 255.255.0.0	1 = 128.0.0.0	17 = 255.255.128.0	2 = 192.0.0.0	18 = 255.255.192.0	3 = 224.0.0.0	19 = 255.255.224.0	4 = 240.0.0.0	20 = 255.255.240.0	5 = 248.0.0.0	21 = 255.255.248.0	6 = 252.0.0.0	22 = 255.255.252.0	7 = 254.0.0.0	23 = 255.255.254.0	8 = 255.0.0.0	24 = 255.255.255.0	9 = 255.128.0.0	25 = 255.255.255.128	10 = 255.192.0.0	26 = 255.255.255.192	11 = 255.224.0.0	27 = 255.255.255.224	12 = 255.240.0.0	28 = 255.255.255.240	13 = 255.248.0.0	29 = 255.255.255.248	14 = 255.252.0.0	30 = 255.255.255.252	15 = 255.254.0.0	31 = 255.255.255.254
0 = Reserved	16 = 255.255.0.0																																	
1 = 128.0.0.0	17 = 255.255.128.0																																	
2 = 192.0.0.0	18 = 255.255.192.0																																	
3 = 224.0.0.0	19 = 255.255.224.0																																	
4 = 240.0.0.0	20 = 255.255.240.0																																	
5 = 248.0.0.0	21 = 255.255.248.0																																	
6 = 252.0.0.0	22 = 255.255.252.0																																	
7 = 254.0.0.0	23 = 255.255.254.0																																	
8 = 255.0.0.0	24 = 255.255.255.0																																	
9 = 255.128.0.0	25 = 255.255.255.128																																	
10 = 255.192.0.0	26 = 255.255.255.192																																	
11 = 255.224.0.0	27 = 255.255.255.224																																	
12 = 255.240.0.0	28 = 255.255.255.240																																	
13 = 255.248.0.0	29 = 255.255.255.248																																	
14 = 255.252.0.0	30 = 255.255.255.252																																	
15 = 255.254.0.0	31 = 255.255.255.254																																	
P0849	Gateway 1	0 a 255																																
P0850	Gateway 2	0 a 255																																
P0851	Gateway 3	0 a 255																																
P0852	Gateway 4	0 a 255																																

Figure ?? illustrates an Ethernet network among the CFW11 inverters using all the communication modules. .

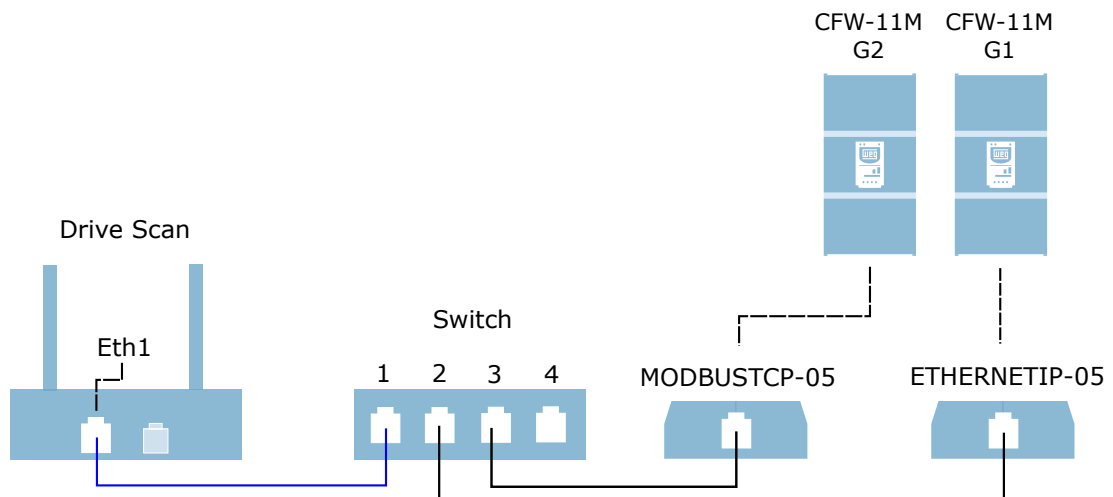
Figure 5.12: Ethernet network among several CFW11M and a Drive Scan

Note that to establish a network with more than one inverter, it is necessary to use a switch. It is important to remember that the inverters in an Ethernet network must have different IP values.

5.9.3 POSSIBLE FORMS OF CONNECTIONS

Figure ?? illustrates the possible ways to connect the CFW11 to the Drive Scan..

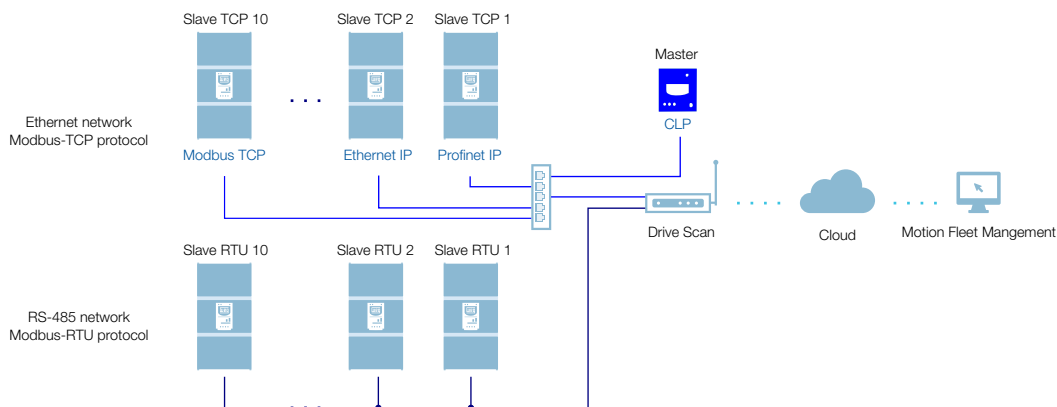

Figure 5.13: Possible connections with the CFW11M

5



WARNING!

The Drive Scan can only be connected to the internet using the Ethernet port GbE0 if the network does not have a proxy.

5.9.4 MONITORING

The Drive Scan continuously monitors the CFW11 parameters specified in [Section ?? ?? on page ??](#). After a cycle of all those readings, as well as of the other assets connected to the Drive Scan, a new reading cycle starts automatically.

The parameters read are transformed into attributes, which can be:

- Only at initialization;
- Last value read;
- Average value;
- Minimum value;
- Maximum value.

Every 5 minutes, the Drive Scan publishes the attributes to the WEG Fleet Management platform. In case of an internet connection failure, the Drive Scan stores the data for up to 30 days in the internal memory, publishing it to the MFM when the connection is reestablished.

In case the CFW11M fails, the Drive Scan automatically publishes the parameters specified in [Section ?? ?? on page ??](#) asynchronously, that is, without waiting for the normal cyclical period of publication.

5.9.4.1 CFW11M Cyclically Monitored Attributes

Parâmetro	Descrição	Atributo	Tipo de aquisição	Classe
P0202	Control type	controlType	Inicialização	identification
P0295	Inverter rated current	inverterRatedCurrent	Inicialização	
P0296	Inverter rated voltage	inverterRatedVoltage	Inicialização	
P0401	Motor rated current	motorRatedCurrent	Inicialização	
P0402	Motor rated speed	motorRatedSpeed	Inicialização	
P0400	Motor rated voltage	motorRatedVoltage	Inicialização	
P0023	Software version	softwareVersion	Inicialização	
P0297	Switching frequency	switchingFrequency	Inicialização	
P0001	Motor speed reference	motorSpeedReferenceAvg	Valor médio	status
P0680	Status word	statusWord	Último valor	
P0042	Enabled hours	enabledHours	Último valor	diagnostic
P0048	Present alarm	presentAlarm	Último valor	
P0049	Present fault	presentFault	Último valor	
P0004	DC link voltage	dcLinkVoltageAvg dcLinkVoltageMin dcLinkVoltageMax	Valor médio Valor mínimo Valor máximo	measurement
P0003	Motor current	motorCurrentAvg motorCurrentMin motorCurrentMax	Valor médio Valor mínimo Valor máximo	
P0005	Motor frequency	motorFrequencyAvg motorFrequencyMin motorFrequencyMax	Valor médio Valor mínimo Valor máximo	
P0037	Motor overload	motorOverloadAvg motorOverloadMin motorOverloadMax	Valor médio Valor mínimo Valor máximo	
P0002	Motor speed	motorSpeedAvg	Valor médio	
P0009	Motor torque	motorTorqueAvg motorTorqueMin motorTorqueMax	Valor médio Valor mínimo Valor máximo	
P0007	Motor voltage	motorVoltageAvg motorVoltageMin motorVoltageMax	Valor médio Valor mínimo Valor máximo	
P0010	Output power	outputPowerAvg outputPowerMin outputPowerMax	Valor médio Valor mínimo Valor máximo	
P0030	Module temperature	moduleTemperatureAvg	Valor médio	temperature
P0018	Analog input 1	analogInput1	Último valor	io
P0019	Analog input 2	analogInput2	Último valor	
P0014	Analog output 1	analogOutput1	Último valor	
P0015	Analog output 2	analogOutput2	Último valor	
P0012	Digital inputs	digitalInputs	Último valor	
P0013	Digital outputs	digitalOutputs	Último valor	

5.9.4.2 CFW11M In Eventos Monitored Attributes

Parâmetro	Description	Attribute	Acquisition type	Class
P0090	Current at Last Fault	faultCurrent	Last value	Event
P0091	DC Link at Last Fault	faultCC	Last value	Event
P0092	Speed at Last Fault	faultVelocity	Last value	Event
P0093	Reference at Last Fault	faultReference	Last value	Event
P0094	Frequency at Last Fault	faultFrequency	Last value	Event
P0095	Motor Voltage at Last Fault	faultVoltageMotor	Last value	Event
P0096	Digital Input States at Last Fault Falha	faultDI	Last value	Event



6 SETTING THE DRIVE SCAN ON THE MFM

Before starting to make the Drive Scan settings, it is necessary to register all assets that will be monitored through the Drive Scan on the WEG Motion Fleet Management platform ([Chapter 3](#)).

The Drive Scan can be connected to the internet and MFM platform by setting and using the Drive Scan Wi-Fi antenna or by connecting a network cable to the GbE0 ethernet port.

For the Drive Scan configuration, follow the instructions below:

- Step 1
(via
Ethernet)** Connect an Ethernet cable between the computer and the Drive Scan GbE0 port (located next to the power supply connector), as shown in [Figure 6.1](#).



Figure 6.1: Preparing for the Drive Scan configuration

Step 1 (via Wi-Fi AP) With Drive Scan turned on and nearby, access the list of available Wireless devices (Windows), as per [Figure 6.2](#). In the case illustrated as an example, the Drive Scan access point has the network named “Drive Scan - 28:0F:76”.

Click on “Connect”.

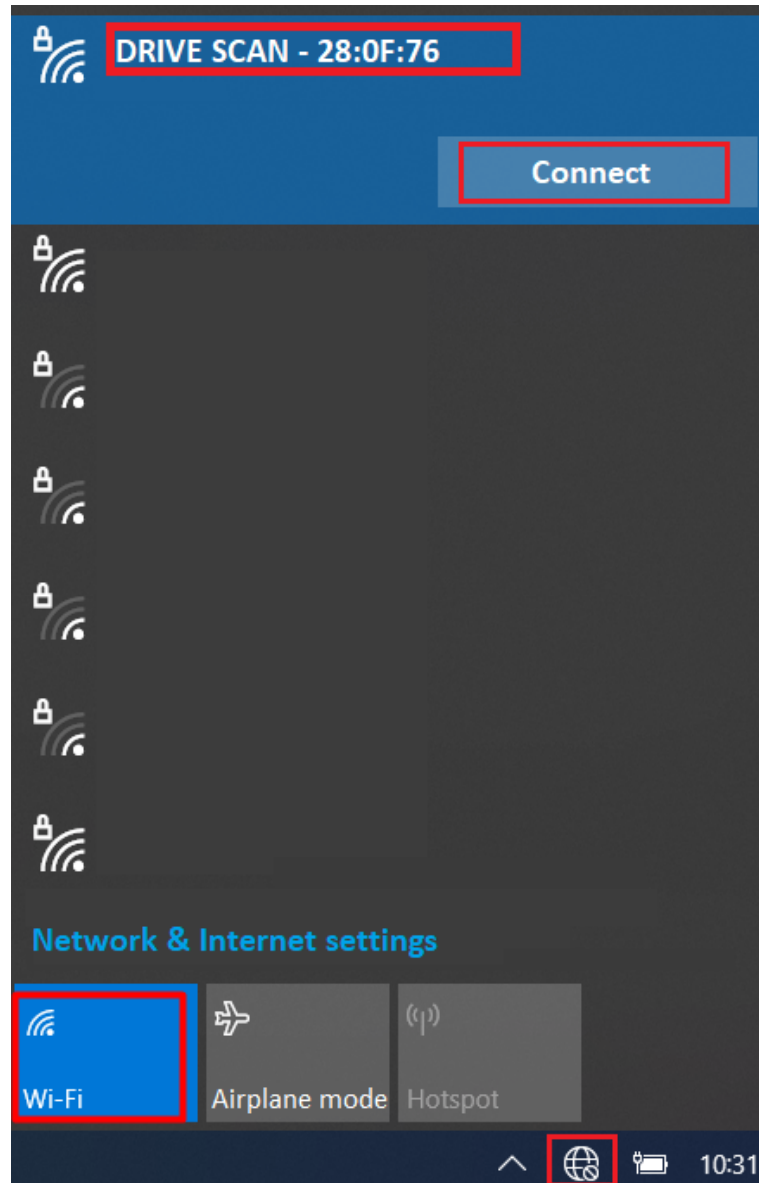

Figure 6.2: Preparing for the Drive Scan configuration

The Wi-Fi password is based on the MAC present on the label located under the Drive Scan. Enter the MAC with lowercase letters and removing the colons.

For example, if the label MAC address is 00:01:C0:28:0F:76, then the Wi-Fi password must be **0001c0280f76**.

- Step 2 (via Ethernet)** Open a web browser on your computer.
 Enter the default Ethernet IP, **192.168.0.10**, into the address bar, as shown in [Figure 6.5](#).
 Press the <Enter> key.

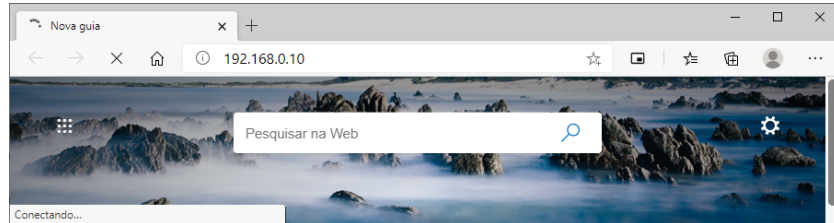

Figure 6.3: Connecting to the Drive Scan via Ethernet

- Step 2 (via Wi-Fi AP)** Open a web browser on your computer.
 Enter the default Wi-Fi IP, **10.10.10.1**, into the address bar, as shown in [Figure 6.4](#).
 Press the <Enter> key.

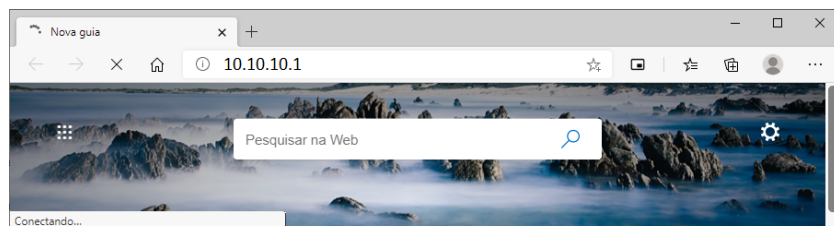

Figure 6.4: Connecting to the Drive Scan via Wi-Fi

- Step 2** Open a web browser on your computer.
 Enter the default IP, **192.168.0.10**, into the address bar, as shown in [Figure 6.5](#).
 Press the <Enter> key.

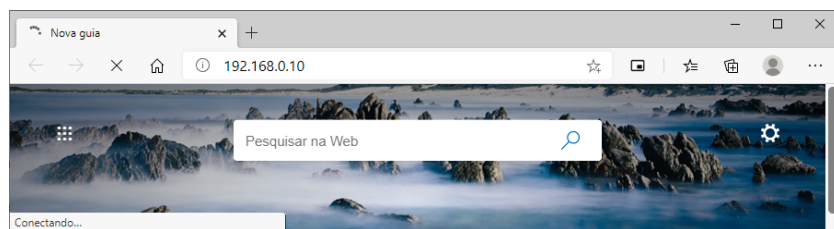

Figure 6.5: Connecting to the Drive Scan

Step 3 If you are configuring Drive Scan via Ethernet cable and the login page, shown in [Figure 6.6](#), does not appear, reset your computer IP address to the same IP range as the Drive Scan. This manual has an appendix ([Chapter A](#)) with instructions regarding this procedure for Windows 10.

Counterwise, authenticate the Drive Scan, which by default is:
If the login page, shown in [Figure 6.6](#), does not appear, reset your computer IP address to the same IP range as the Drive Scan. This manual has an appendix ([Chapter A](#)) with instructions regarding this procedure for Windows 10.

Authenticate the Drive Scan, which by default is:

- User: **weg**
- Password: **weg**

Click on “Login” button.

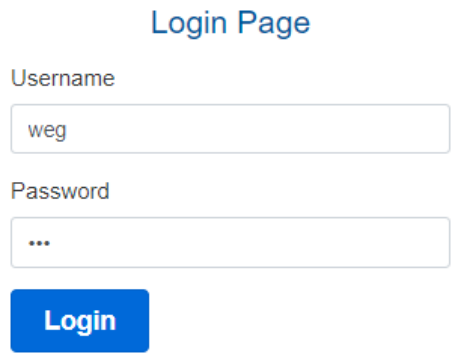

Figure 6.6: Authenticating to the Drive Scan

Step 4 Click on the “CONFIGURATION” tab, as shown in [Figure 6.7](#).

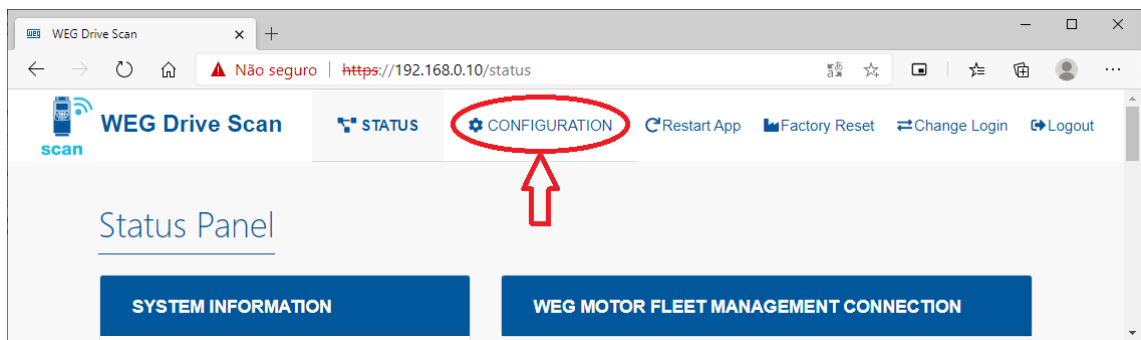

Figure 6.7: Drive Scan Status

Step 5 Check the “Internet Status” field. If the status read is:

“Connected”: go to **Step 8**; or

“Disconnected”: go to **Step 6**, as shown in [Figure 6.8](#).

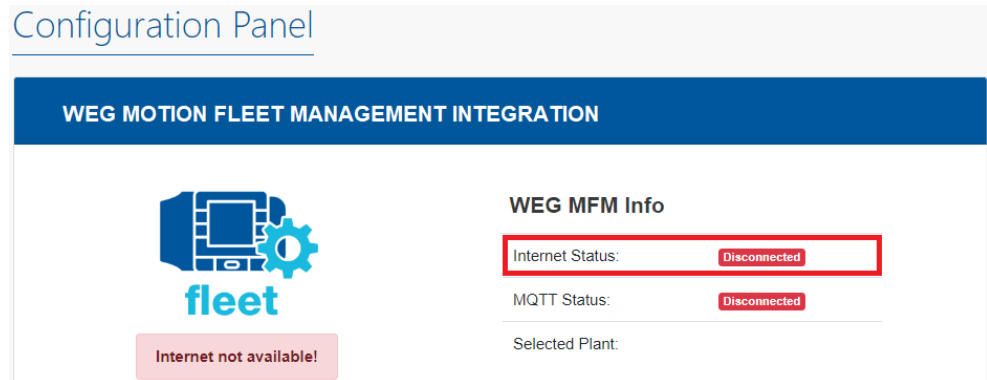

Figure 6.8: checking the Drive Scan configuration

Step 6 Make the settings for the connection to the Wi-Fi internet network, as shown in [Figure 6.9](#):

- SSID (Service Set Identifier): Wi-Fi network name;
- Default Route: enable/disable the use of the default network route for the destination address of IP packets;
- Security: defines the Wi-Fi network access protection mode to be used:
 - Open network
 - WPA2-PSK
 - WPA2-Enterprise
 - WEP
- EAP Type: defines the network authentication framework to be used:
 - None
 - PEAP-MSCHAPV2
 - PSK
 - PEAP
 - TTLS-MSCHAPV2
- Identity: username to authenticate to the Wi-Fi network
- Password: password or pin to authenticate to the Wi-Fi network

Figure 6.9: Wi-Fi network internet configuration

Go to the bottom of the page and click on the “Save Configuration” button ([Figure 6.10](#)).

Go to **Step 7**.

If the connection is via ethernet port GbE0 ([Figure 6.1](#)) e avance ao **Step 17**.



Figure 6.10: “Save Configuration” button

Step 7 A pop-up window will inform you that the configuration has been saved, as shown in Figure 6.11.

Then wait for the Drive Scan to restart, as shown in Figure 6.12.

Return to **Step 3**.



Figure 6.11: Information about the saving operation

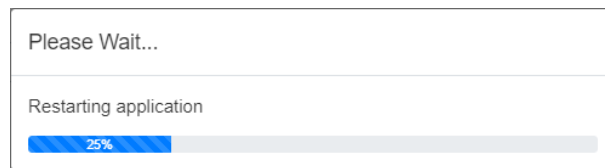

Figure 6.12: Drive Scan resetting

Step 8 The “Internet Status” field should display “Connected”.

Check if the fields (Figure 6.13): “MQTT Status” displays “Disconnected” or “Selected Plant” is blank or displays the wrong plant:

- Click on the “Configure WEG MFM” button
- Go to **Step 9**

Otherwise (if the fields above are correct):

- Go to **Step 15**

Configuration Panel

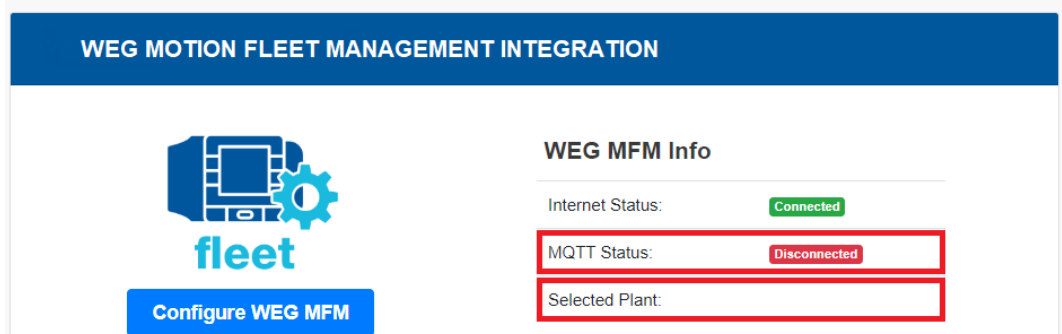

Figure 6.13: Linking of the Drive Scan to the MFM

Step 9 Enter your login and password previously registered on the MFM (Chapter 3) and click on “Next”, according to Figure 6.14.

Figure 6.14: MFM Email and password login fields

Step 10 If successful, go to **Step 11**.

In case of failure (Figure 6.15) (wrong login or password), click on the “Back” button and return to **Step 9**.

Figure 6.15: Invalid MFM email or password

Step 11 Drive Scan configuration wizard for the MFM.

Select the task:

- “Manage Plants”: links the Drive Scan to a plant; or
- “Delete Device”: deletes the Drive Scan from the plant.

Clique no botão:

- “Next”:
 - Go to **Step 12** (if “Manage Plants” option - [Figure 6.16](#));
 - Go to **Step 14** (if “Delete Device” option).
- “Back”: return to **Step 9**.

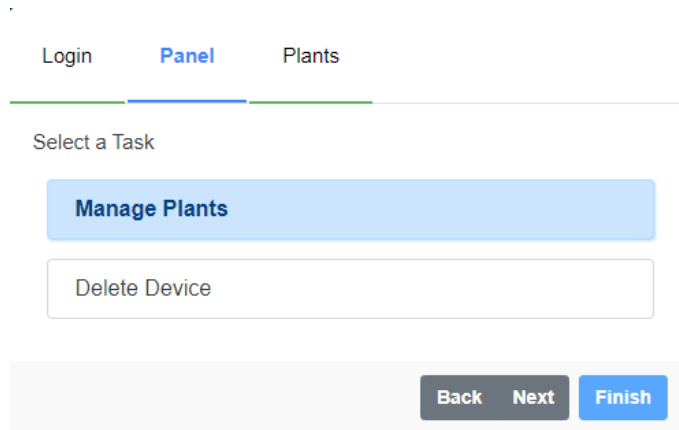

Figure 6.16: Task selection to the MFM of the Drive Scan

Step 12 The plants previously registered on the MFM, as per Chapter 2, are displayed.

Select the plant this Drive Scan should be linked to. If no plant is selected, the system will not advance.

Then, select one of the actions for the plant:

- “Create Device”: links the Drive Scan as a new gateway on MFM;
- “Replace Device”: replaces the Drive Scan with another existing gateway on MFM.

Clique no botão:

- “Next”:
 - Go to **Step 13** (if “Create Device” option - [Figure 6.17](#));
 - Go to **Step 14** (if “Replace Device” option);
- “Back”: return to **Step 11**.

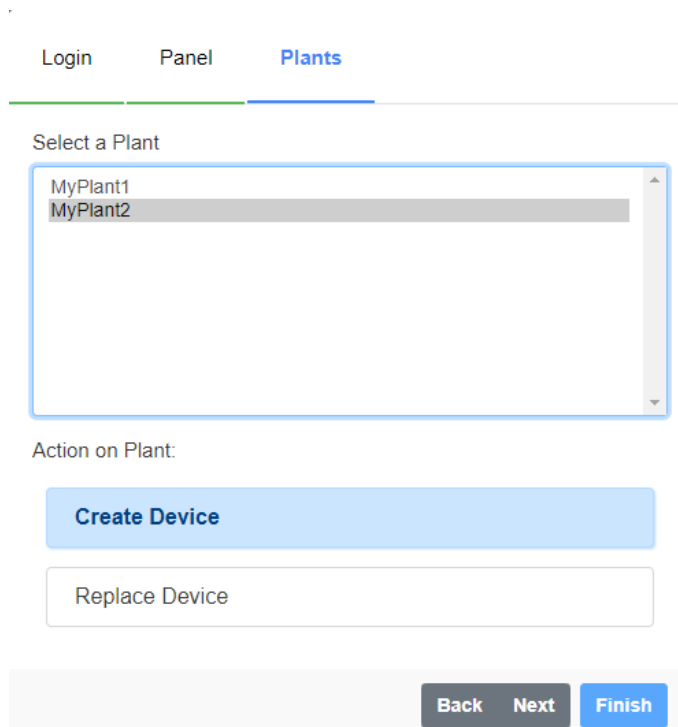

Figure 6.17: Action on the plant of the Drive Scan MFM

Step 13 Step 13 It is informed that the Drive Scan will be created in the MFM after the configuration is saved, as shown in [Figure 6.18](#).

Click on the button:

- “Back”: return to **Step 12**;
- “Finish”: finishes the wizard and advances to **Step 16**.

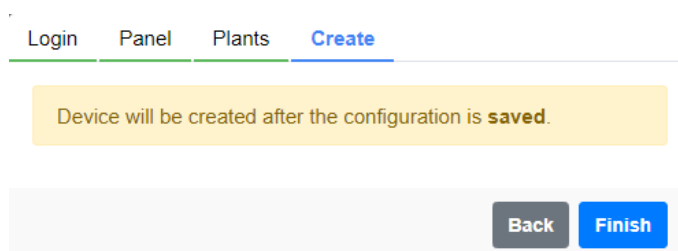

Figure 6.18: Information about creating the Drive Scan MFM

Step 14 Confirmation is required to unlink the Drive Scan from the MFM, as shown in [Figure 6.19](#).

Click on the button:

- “Delete”: Go to **Step 15**;
- “Back”: return to **Step 11**.

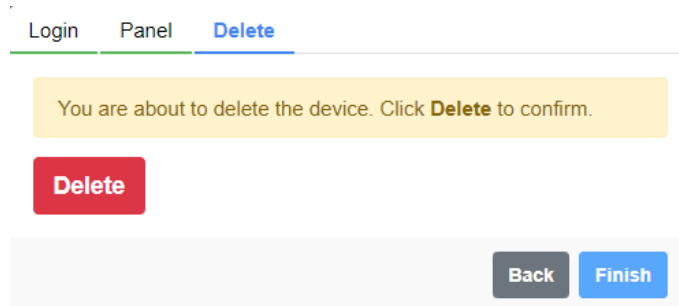

Figure 6.19: Screen with information on unlinking the Drive Scan from the MFM

Step 15 If successful, proceed to **Step 16**. If an error message pops up (Figure 6.20), check its content and click on:

- “Back”: return to **Step 11**.

If the error persists:

- return to the configuration tab;
- use the Factory Reset option (Figure 6.21);
- return to **Step 1**, it is necessary to redo all the settings.

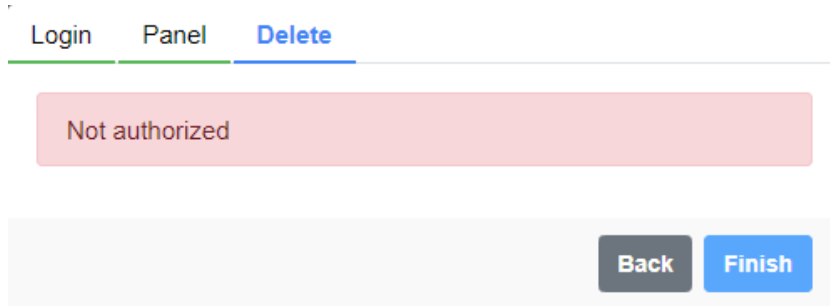

Figure 6.20: Failed to unlink the Drive Scan from the MFM

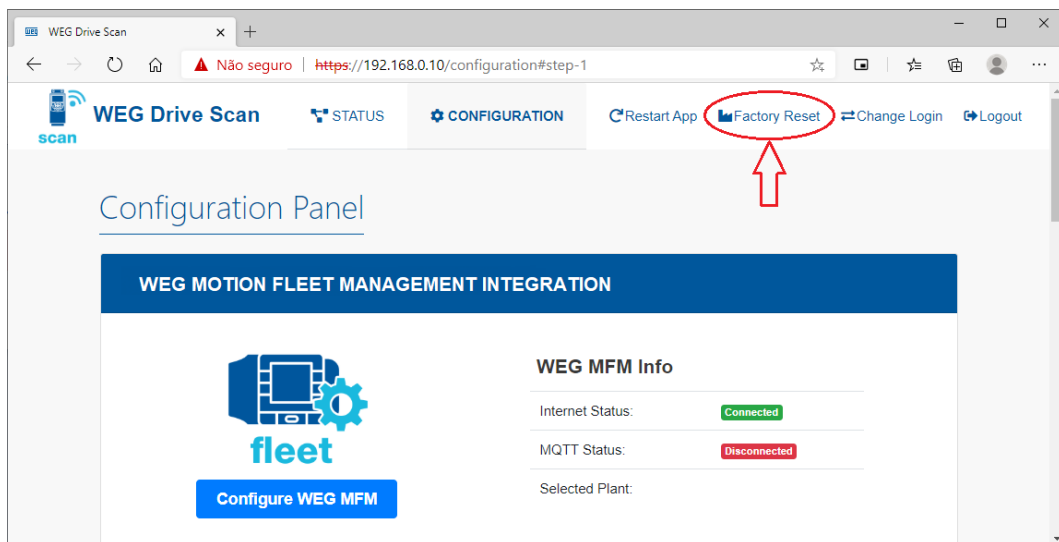

Figure 6.21: Command to reset the Drive Scan to factory default

Step 16 The new plant must have been configured (Figure 6.22).

Click on the “Save Configuration” button (Figure 6.10).

Wait for the Drive Scan to restart (Figure 6.12).

Go to **Step 17**.

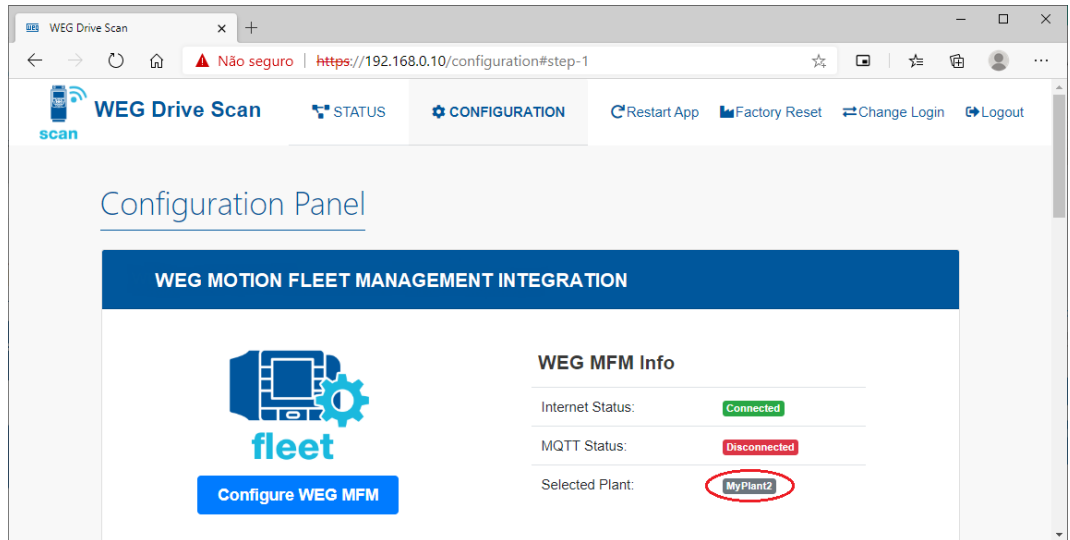

Figure 6.22: Plant linked to the Drive Scan on the MFM

Step 17 The Drive Scan is already properly configured on the MFM (Figure 6.23).

Configure the Eth1 Ethernet network interface (Figure 6.24).

- Use DHCP: enable/disable the use of DHCP;
- Default Route: enable/disable the use of default network route for the destination address of the IP packets;
- IP Address: Ethernet interface IP address;
- Network Mask: network mask related to the IP address of the Ethernet interface;
- Gateway: Gateway network IP address;
- DNS 1: First DNS server IP;
- DNS 2: Second DNS server IP.

Configure the RS-485 serial network interface (Figure 6.25).

- Speed: baudrate;
- Bits: number of communication bits;
- Parity: communication parity:
 - none,
 - even,
 - odd
- Stop bits: number of communication stop bits.

Click on “Save Configuration” (Figure 6.25).

Wait for the Drive Scan to restart, and it will be ready to be operated (Figure 6.23).

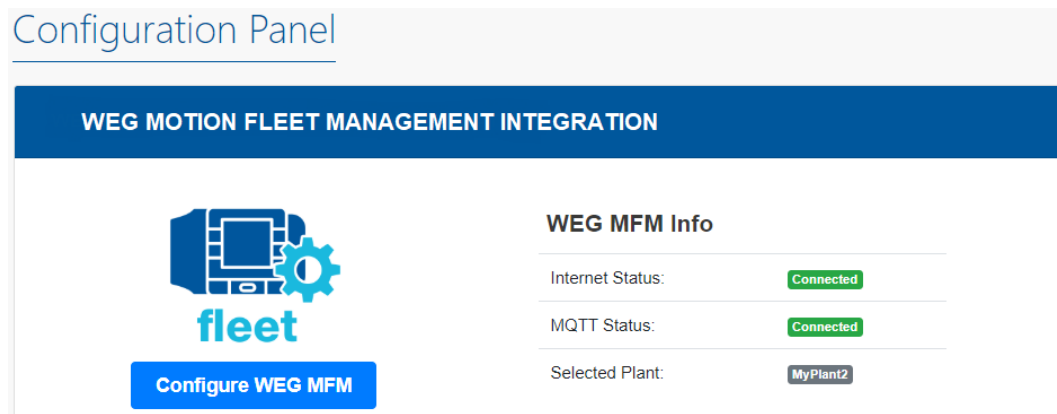

Figure 6.23: Drive Scan linked to the MFM

Interface Eth1 On

Use DHCP: Default Route:

IP Address: Network Mask: Gateway:

Additional DNS On

DNS 1: DNS 2:

Figure 6.24: Ethernet network configuration

SERIAL INTERFACES

Interface RS485 On

Speed: Bits: Parity: Stop bits:

Figure 6.25: RS-485 network configuration



7 MONITORING DASHBOARD

7.1 ACCESS

1. Access the website of the WEG Motion Fleet Management platform at <http://mfm.wnology.io>,
2. Enter your email and login, and press the <Enter> key,
3. Click on the "Systems" side tab, and keep clicking on each sublevel until you find your asset,
4. In the plant, select the asset to be monitored.

7.2 FEATURES

Remote asset monitoring provides the customer with enormous potential for cost reductions, especially when aspects related to maintainability and productivity are assessed.

The dashboards of assets monitored by the WEG Motion Fleet Management platform are constantly evolving, increasing the user experience in data reception.

In all dashboards, we will bring direct information about:

- Identification of each asset;
- Asset status;
- Asset health;
- Charts of the various monitored attributes;
- Parameter history (only available for the CFW11).

The user can also create minimum and maximum limits for several monitored variables for each asset, allowing actions to be taken when values are exceeded. In addition, alerts are automatically generated when asset failures occur.

The tool also allows registering and scheduling maintenance events for each of your assets being monitored.

7.3 PARAMETERS

Currently available only for the CFW11 frequency inverter, the "Parameters" dashboard, accessible via the "Maintenance" tab, allows the user to view the values of the drive configuration parameters. Parameter data is shown in a table with the following information:

- Parameter;
- Description;
- Reference;
- Current;
- Status.

Figure 7.1 illustrates the functionality.



Filter				
Parameter	Description	Reference : 30/06/2021 14:48:46	Current : 30/06/2021 18:18:12	Status: 5/426
P0000	Access to parameters	5	5	No change
P0023	Software version	6	6	No change
P0027	Accessories config. 1	0	0	No change
P0028	Accessories config. 2	208	208	No change
P0029	Power HW config.	50176	50176	No change
P0100	Acceleration time	38.6 s	35 s	Changed

Figure 7.1: Parameters table

In the table, it is possible to check the parameters, their descriptions, values corresponding to a reference date and to the current date (or date of the last reading). In the dashboard, the user is still able to assign, through the button “Assign reference”, a reference date to compare the parameter values of the chosen date with the current values. Through the “Request parameterization reading” button, it is possible to request the reading of the parameters, inserting them as current values in the table. Such event can be repeated once every 10 minutes.

The result of comparing parameter values between the reference date and the current date is listed in the “Status” column. The “Status” can be “No Change”, when there is no divergence between the values read on the two dates, or it can be “Changed”, when there is divergence in the values read.

8 DRIVE SPECIALIST

The Drive Specialist is a Motion Fleet Management module that adds to the Drive Scan advanced diagnostic functionalities of the CFW11 frequency inverters using specific information and know-how. This module provides the CFW11 with comprehensive health status diagnostics, relating power, ventilation and temperature elevation variables, as well as information on electricity consumption.

8.1 COMPATIBILITY

- Drive Scan-DSL-2P2SE-2-POE ≥ V1.3.0
- Wnology/edge-agent ≥ V1.22.1
- Scan Application ≥ V1.5.0
- Motion Fleet Management ≥ V1.5.14

8.2 CFW11 FREQUENCY INVERTER

The Specialist module is subdivided into the following pages:

- Consumption,
- Diagnostic

8.2.1 Consumption

The Consumption page displays information on the inverter electrical energy consumption. This energy is basically related to the mechanical power delivered by the motor driven by the inverter.

The user can view the inverter electrical energy consumption by periods and have an idea of the costs of this energy, based on the cost per kWh setting. [Figure ??](#) illustrates the functionality considering a cost of \$0.35 per kWh.

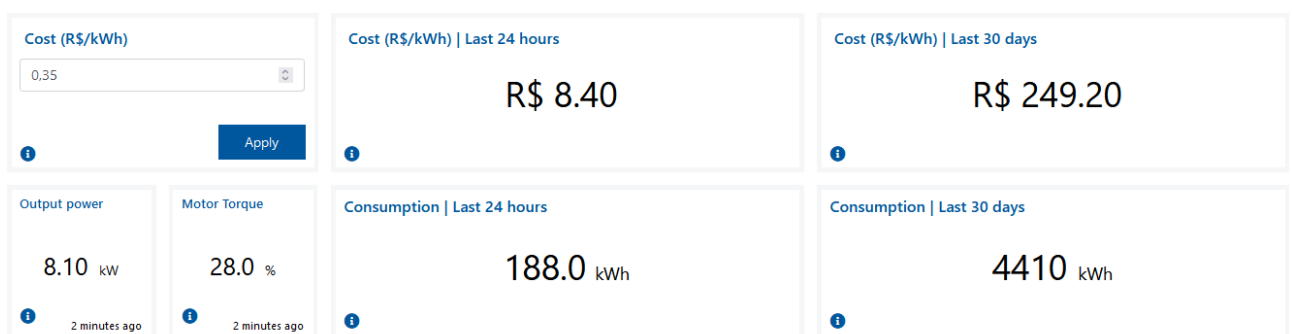

Figure 8.1: Drive Specialist consumption page

On the same page, it is possible to view charts of consumption vs. cost history by period and all measurements related to the asset energy consumption, such as motor speed, output power and torque. Notes on the power indication (based on the content of parameter P0010 in kW):

1. The indicated power is the active electrical power at the output of the inverter, given by:

$$P0010 = \sqrt{3} \times P0007 \times P0003 \times P0011 \tag{1}$$

Where P0010 is the power (kW), P0007 is the voltage (V), P0003 is the current (A) and P0011 is the power factor.

2. This power will be the mechanical power plus the power dissipated in the motor (motor losses).
3. The lower the speed and load, the greater the difference between the electrical power at the inverter output and the mechanical power. This situation can be seen in the charts of Figure ??.

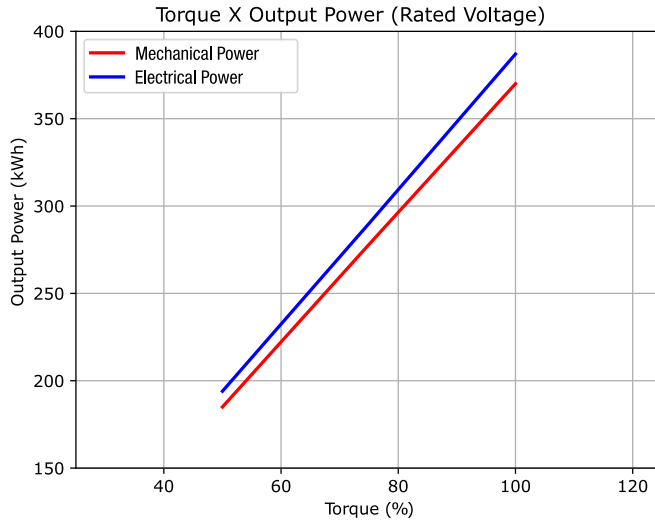

(a) Rated speed

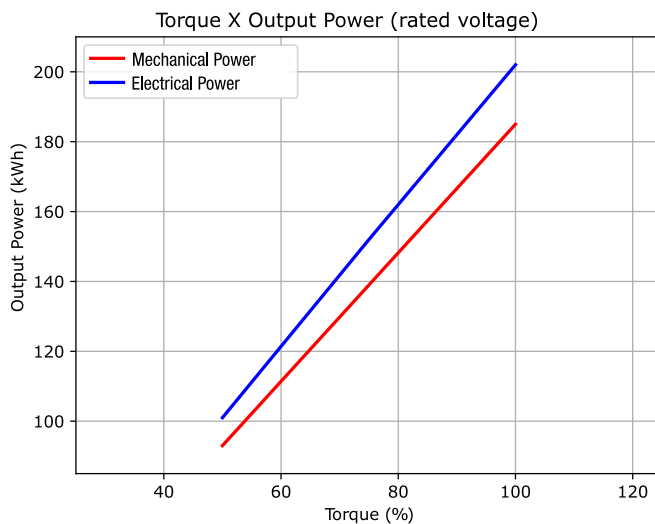

(b) Half rated speed

Figure 8.2: Example of the difference between mechanical power and electrical power at the inverter output – W22 IR3 Premium Motor, 500 CV, 4 Poles – measurement error not included

The data used for the chart (a) of Figure ?? is described in Table ??.

Table 8.1: Torque X Power curve information for rated speed

Load (%)	Efficiency	Mechanical power (kW)	Motor losses with drive (kW)	Electric power (kW)
50%	96,0%	185	8,86	194
75%	96,1%	278	12,95	290
100%	96,2%	370	16,81	387

The data used for the chart (b) of Figure ?? is described in Table ??.

Table 8.2: Torque X Power curve information for half rated speed

Load (%)	Efficiency	Mechanical power (kW)	Motor losses with drive (kW)	Electric power (kW)
50%	96,0%	93	8,87	101
75%	96,1%	139	12,95	152
100%	96,2%	185	16,81	202

8.2.2 Diagnostic

The Diagnostic page presents a health analysis of the inverter (Figure ??), evaluating the risk of its shutdown due to the conditions of the AC power supply and the fans that cool the power semiconductors.

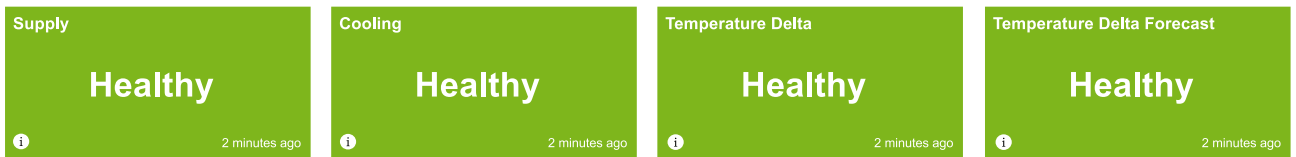
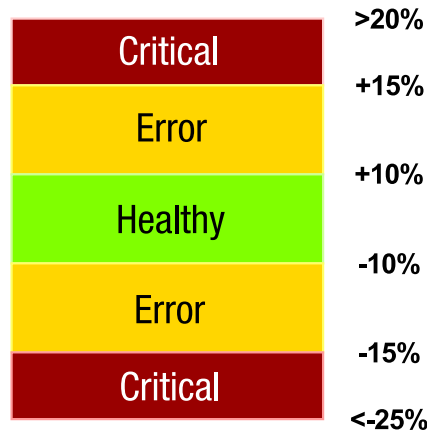

Figure 8.3: Example of inverter health information flagged on the Diagnostic tab

8.2.2.1 Power supply

The quality of the AC power supply is assessed through the reading of the inverter DC link voltage. The average voltage of the DC link is directly related to the amplitude of the AC power supply (effective value). During braking moments, that is, when the motor connected to the inverter output works as a generator, the DC link voltage is no longer defined by the AC power supply.

F022 DC Link Overvoltage



F021 DC Link Undervoltage

Figure 8.4: Indication of the power supply quality in relation to the effective AC power supply

The amplitude of the voltage ripple, especially the amplitude of the second harmonic (100 Hz for 50 Hz AC power supply and 120 Hz for 60 Hz AC power supply), is directly related to the phase balance of the three-phase supply voltages (Figure ??). In addition to the risk of the inverter going into fault mode due to high voltage ripple (F006 Imbalance Phase Loss in the AC Power Supply), operation for a long time under conditions of greater voltage imbalance may bring the following undesired effects:

- Reduced service life of the DC link capacitors and inductors due to higher ripple current;
- Electrical protection devices connected to the inverter input, such as overload relays and fuses, may trip due to higher values of current peaks and effective currents in the AC power supply and greater voltage imbalance (Figure ??).

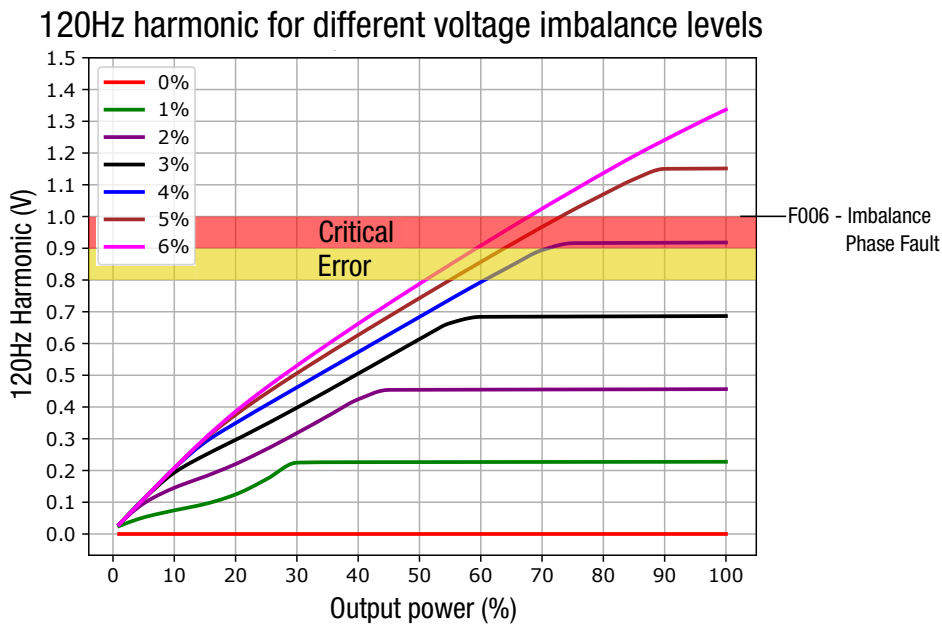

Figure 8.5: Indications of power quality in relation to the AC power supply phase balance - examples for 60 Hz power supply

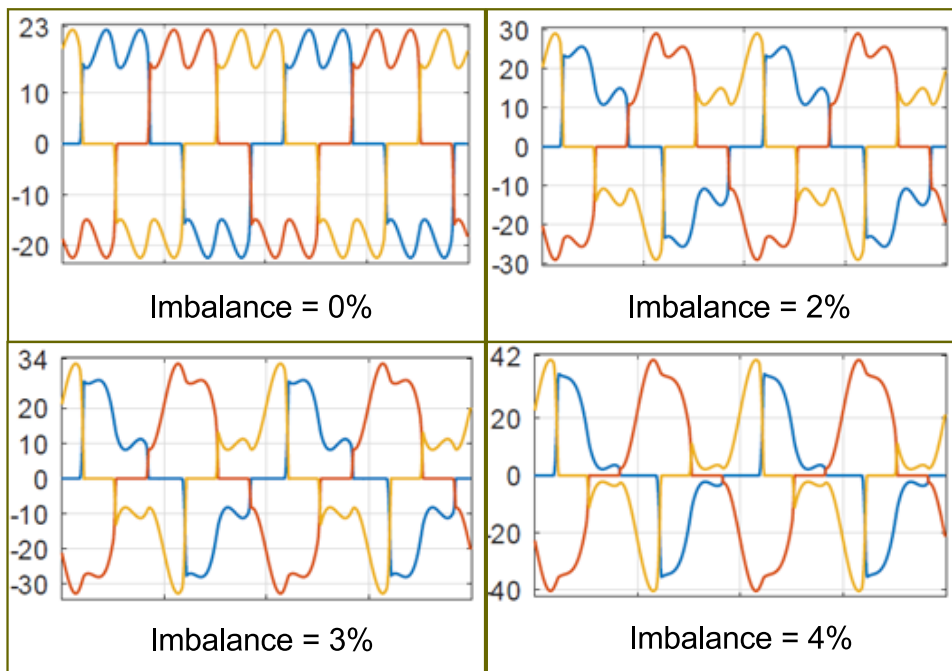

Figure 8.6: Current waveforms I_R , I_S e I_T in the AC power supply as a function of the imbalance of the power supply phases - examples for 60 Hz supply

The values of currents I_R , I_S e I_T in the AC power supply as a function of the imbalances of power supply phases can be seen in Table ??.

Table 8.3: Values of I_R , I_S e I_T in the AC power supply as a function of the imbalances of power supply phases – 60 Hz frequency

Voltage imbalance	I Max RMS	I Min RMS	I Max Peak	I_R	I_S	I_T
0%	15A	15A	22A	15A	15A	15A
2%	19A	15A	29A	15A	19A	15A
3%	20A	15A	33A	16A	20A	15A
4%	22A	16A	36A	16A	22A	16A

8.2.2.2 Cooling

The fans that cool the power part of the inverters are fundamental for the safe operation of the power semiconductors and guarantee the expected service life of the internal parts of the inverters. Air flow is a fundamental factor for proper cooling. When mounting inverters in panels with a high protection rating, input and output filters may restrain the cooling air flow. Dust buildup in the air filters of such panels is a common cause of temperature rise in inverters. A malfunction of the cooling system may lead to the indication of a fault in the inverters due to overtemperature, namely:

- F011 - Rectifier Overtemperature,
- F051 - IGBTs U Overtemperature,
- F054 - IGBTs V Overtemperature,
- F057 - IGBTs W Overtemperature,
- F153 - Internal air Overtemperature,
- F183 - IGBTs overload + Temperature

The fans used in the CFW11 inverters are of the “Dual Bal Bearing” type with DC power and with “3 wires”, for their power supply and speed measurement. The fan manufacturer specifies its service life, estimated in hours, considering environmental conditions such as maximum temperature and degree of air pollution. For example, a pollution degree 2 non-conductive pollution as per EN50178 and UL508C. In case the fan exceeds this number of operating hours, it may malfunction, mainly of a mechanical order. A very common cause is the degree of air pollution in industrial applications exceeding the specification.

On the Diagnostic tab, you can see values specified for the fans as shown in [Figure ??](#):

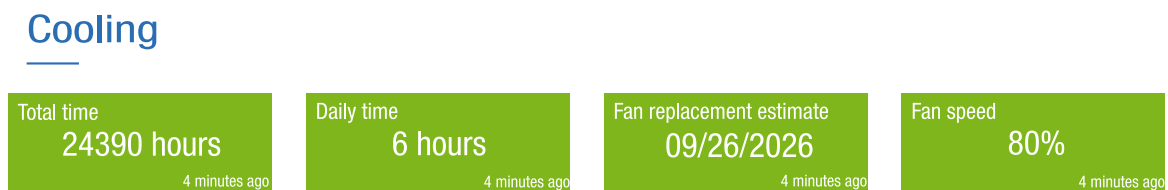

Figure 8.7: Indications related to the health of fans

Cooling health indications are described below:

- Total time: total time in hours that the fan had been running. Note that the inverter automatically turns the fans on and off depending on the inverter internal temperature;
- Daily time: average number of hours the fan had been running per day. This value is updated daily and is used to estimate the fan replacement time;
- Replacement estimate: is the estimated date on which the fan must be replaced, that is, when it reaches its lifespan (provided by the manufacturer). This date is calculated and updated each day, subtracting the time (in hours) of the fan’s lifetime by the fan’s operating time from its beginning to the present moment, and in this way, a prediction of the number of days remaining is made considering the average daily hours of operation.

Note that the service life will be valid if the fan is used in environmental conditions within the limits specified by the manufacturer. The fan model varies according to the CFW11 model and the service life information of the monitored model comes from a database stored in WEGnology.

The Normal (green), Alert (yellow) and Critical (red) states are defined by the following criteria:

- Normal: 180 days (from the current date) \leq Replacement date
- Alert: 90 days \leq Replacement date < 180 days,

- Critical: Replacement date < 90 days
- Fan speed: indicates the current fan speed. This speed under normal conditions: environment within the limits specified by the manufacturer and maximum pressure, such that the air flow remains at a minimum value. A drop in the speed below certain values indicates an abnormal fan operation that could lead the drive to an overtemperature fault or a fan speed fault:
 - F174 - Left Fan Speed Fault,
 - F175 - Central Fan Speed Fault,
 - F176 - Right Fan Speed Fault

The indicated states are (Figure ??):

- Normal: $0,85 \times \text{rated speed} \leq \text{fan speed}$,
- Alert: $0,70 \times \text{rated speed} \leq \text{fan speed} < 0,85 \times \text{rated speed}$,
- Critical: if fan speed < $0,70 \times \text{rated speed}$

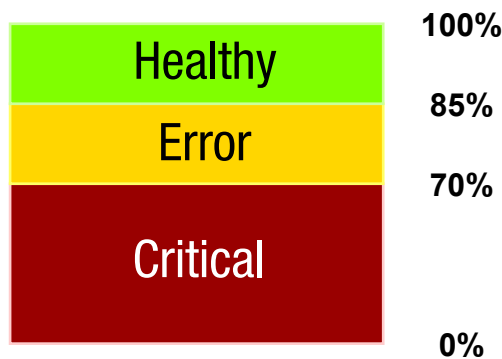

Figure 8.8: indications of the fan speed health status in relation to the rated speed

- Reset after fan maintenance: in case of fan replacement, it will be necessary to reset the service life counter.

8.2.2.3 Temperature Elevation

Stress caused by continuous or intermittent operation at higher temperatures is a major cause of drive failure. Inverter shutdowns due to activation of internal protections or early component failures are often related to high temperature operation.

Drive Specialist temperature diagnostics are based on IGBT’s temperatures and measured ambient temperature. Possible ways of measuring the ambient temperature are shown below.

From these variables, the temperature difference between the IGBT’s and the environment is calculated, here called ΔT . Monitoring the ΔT allows identifying a reduced cooling condition of the inverter or the panel where it is mounted, even if the absolute temperatures have not yet reached critical values.

Through the ΔT behavior curve, the Drive Specialist automatically sets the ALERT and CRITICAL thresholds for the highest daily value of the ΔT . In addition, Drive Specialist predicts the maximum daily ΔT expected for up to the next 5 days (Figure ??). To establish the ΔT prediction, the Drive Scan needs to record at least **25 days** of Temperature Delta data, otherwise the Machine Learning (ML) system will be learning the behavior of the variable (as per Figure ??). The forecast stages can be checked as per Table ??.

Table 8.4: ΔT forecast learning stages

Stage	Days with data
Learning	25
3 days forecast	25 a 40
4 days forecast	40 a 50
5 days forecast	>50

The definition of the thresholds, as well as the predictions of future temperatures, are made based on ML techniques together with statistical algorithms. Below are discussed some important situations involving the prediction of ΔT .

1. ML in learning state:

When there is not enough data record, the ML is in the ΔT learning stage, as shown in the figure below.

Delta temperature - Monthly

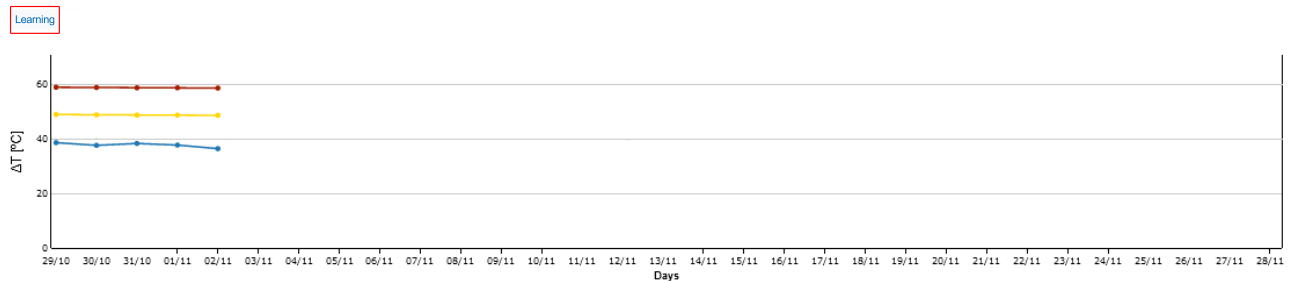

Figure 8.9: Graph with ΔT being learned by the ML algorithm

2. Forecast in progress:

Once 25 days of data is recorded, Drive Specialist begins to perform variable prediction. This can be seen as shown in the figure below.

Temperature Delta - Monthly

Last prediction: 27/10/2021 5 days of forecast

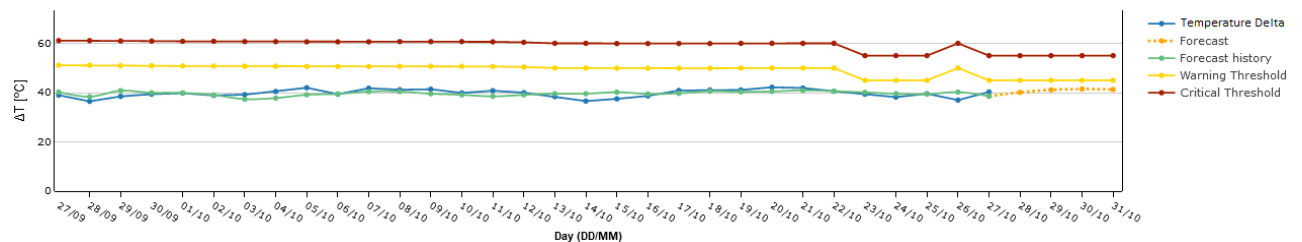

Figure 8.10: Graphs of ΔT values displayed in temperature Elevation diagnostics (ΔT)

The curves represent, respectively,

- Blue: recorded values of maximum ΔT of each day (up to the current day);
- Green: predicted past values of the maximum ΔT of each day;
- Dashed yellow: Maximum ΔT forecast for the next days (3 to 5 days);
- Thresholds:
 - Yellow: Alert level for the maximum ΔT ;
 - Red: Critical level for the maximum ΔT .

3. Forecast with missing data (graph holes):

In certain applications, the frequency inverter may be off for some periods. In the Temperature Delta forecast graph this situation becomes quite apparent. The [Figure ??](#) exemplifies this case.

Delta temperature - Monthly i

Last Forecast: 24/11/2021 5 Forecast days

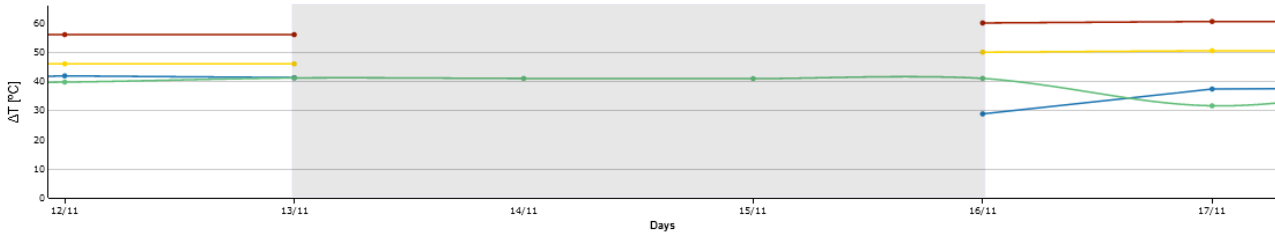

Figure 8.11: Monthly ΔT values graph with missing data

As can be seen in the figure above, the demarcated region represents the period with missing Temperature Delta data, from 13/11 to 16/11.

WARNING!

It should be noted that if the inverter is disabled for a period longer than the prediction days, future predictions will not be performed.

4. ΔT daily graph:

Below the graph of the monthly curves of the Temperature Delta, there is a graph containing the daily curves of the variable (Figure ??).

Delta temperature 24/11/2021

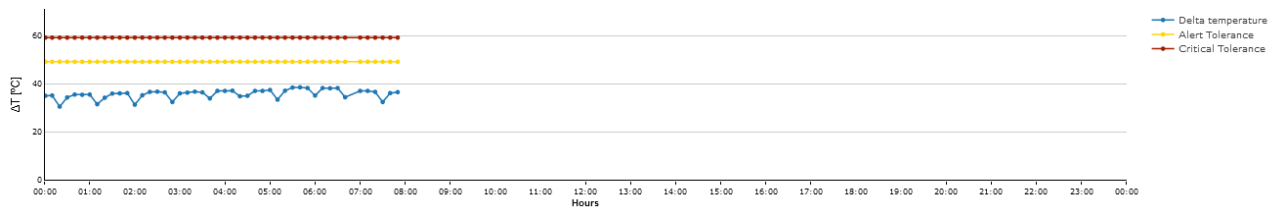

Figure 8.12: Graph of daily ΔT values displayed in Temperature Rise Diagnosis (ΔT)

The curves represent, respectively,

- Blue: maximum ΔT recorded values every 10 minutes (until current time);
- Thresholds:
 - Yellow: ALERT level for maximum ΔT ;
 - Red: CRITICAL level for maximum ΔT .

5. ΔT Threshold levels change warning:

Thresholds are updated daily according to the variation of ΔT . When there is a variation of $\pm 5^\circ\text{C}$ in relation to the reference, the user is notified through a pop-up about this change, as per Figure ??.

⚠ Attention!
✕

Error

Current value: **42.0°C**

Automatic assignment

Do you want to add a new alert threshold?

New value: 50.2°C

Or choose a new value for reference:

°C ⌵

SAVE
CANCEL

Figure 8.13: Warning pop-up about changing ΔT Thresholds

The drive health relative to temperature elevation shown by the Drive Specialist is exemplified in [Figure ??](#). The “Temperature Delta” status indicates health relative to the current measured and calculated values of the Temperature Delta. The “Delta Temperature Prediction” status similarly indicates the health versus up to 5 day forecast for the temperature Delta.

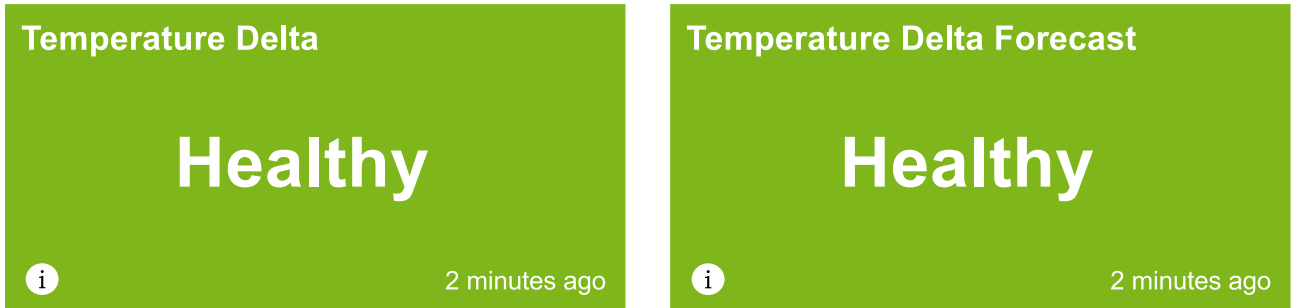

Figure 8.14: Health diagnoses related to temperature elevation (ΔT)

In [Chapter ??](#) are shown the way of acquisition of the ambient temperature by the Drive Specialist.

8.2.2.4 Ways of measuring the environment temperature

To measure the environment temperature, the temperature of the region is used through data from Application Programming Interfaces or, more precisely, the ambient temperature can be directly measured with a temperature sensor.

Drive Specialist has two query API's. The main one is the Weather API and Geolocation which provides very reliable and accurate data and the second is OpenWeather, which works as a backup.

Note that data from API are meteorological data collected from specific points in each city and, even if the query brings the temperature value of the collection point closest to the inverter installation location, there may be slight variations in relation to the location temperature. The second case, the use of a local temperature sensor, is recommended for environments that present temperatures that are very different from the region's temperature, which is often the case for industrial warehouses.

Examples of ambient temperature sensors for use with Drive Specialist are shown as per [Figure ??](#).

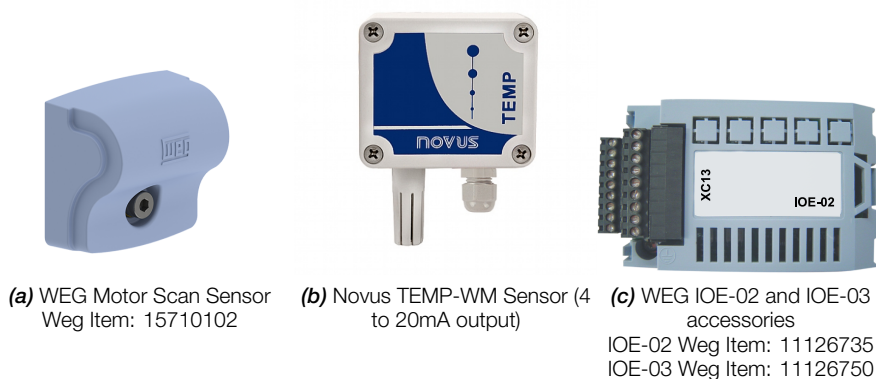

Figure 8.15: Examples of Ambient Temperature Sensors

1. Instructions for using an external temperature sensor:

The environment temperature sensor must be strategically positioned in order to obtain the greatest possible sensitivity in the measurement of the ΔT .

In case the inverter is mounted on wall or flange (air duct), place the sensor close to the inverter cooling air inlet: lower part close to the air inlet and heatsink fan(s).

In case the inverter is mounted in a panel, place the sensor **externally to the panel, very close to its cooling air inlet**, normally located at the bottom of the panel. According to [Figure ??](#), it is possible to see a typical case with WEG Motor Scan, but the same positioning is valid for other sensors.

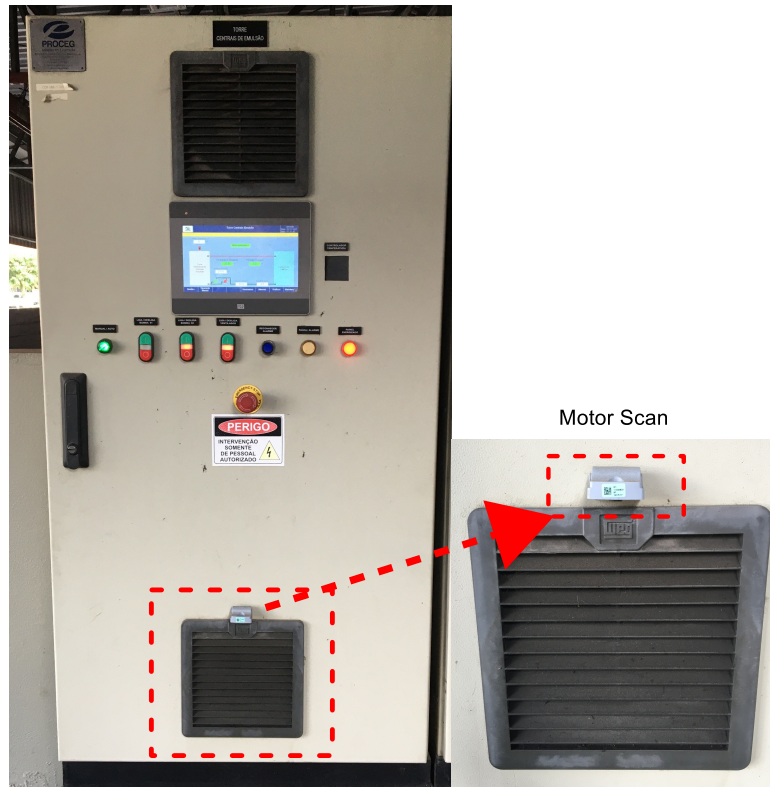

Figure 8.16: Example of the correct positioning of the WEG Motor Scan environment temperature sensor in the case of a panel containing an inverter

a) WEG Motor Scan Sensor:

The WEG Motor Scan sensor can be used for drive environment temperature sensing, with its generic sensor mode.

To use the sensor, it is necessary to have the “Motor Scan” app on the cell phone and configure the Motor Scan as “Other Assets”. The situation can be seen according to page 49 of the document “General Installation and Operation Manual WEG Motor Scan”. It is necessary to pay attention to some details:

- The Motor Scan must be configured in the same plant as the Drive Scan used to monitor the drives,
- It is not necessary to use the Motor Scan fastening screw and bushing,
- In step 7 of the Motor Scan setup, select “Other” as asset.

After the Motor Scan configuration, it is possible to select it as the ambient temperature sensor for the drive. In sequence, open the asset tolerances page and go to the option “Environment temperature data source”. Select “Motor Scan Generic” as the data source. Below the selection, the Motor Scan previously configured should be listed. Finally, it must be selected and confirmed as a data source ([Figure ??](#)).

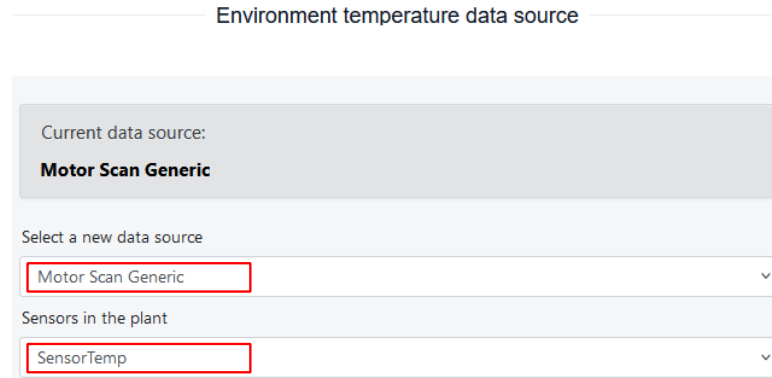

Figure 8.17: Selecting Generic Motor Scan as Environment Temperature Data Source on Asset Thresholds Page

b) Novus Temperature Sensor:

To use the Novus temperature sensor as the CFW11 environment temperature data source, it is possible to connect it to one of the analog inputs available on the drive control board XC1 connector.

It is necessary to supply the sensor with 12Vdc to 30Vdc. It is suggested to supply it by the drive itself, through the 24Vdc source available on the drive (pins 13 and 11 of the XC1 connector). It is recommended to use the AI2 analog input, as it does not have a function by factory default. To use it in 4mA to 20mA mode it is necessary to move DIP switch S1.3 to ON.

Figure ?? illustrates suggested electrical connections.

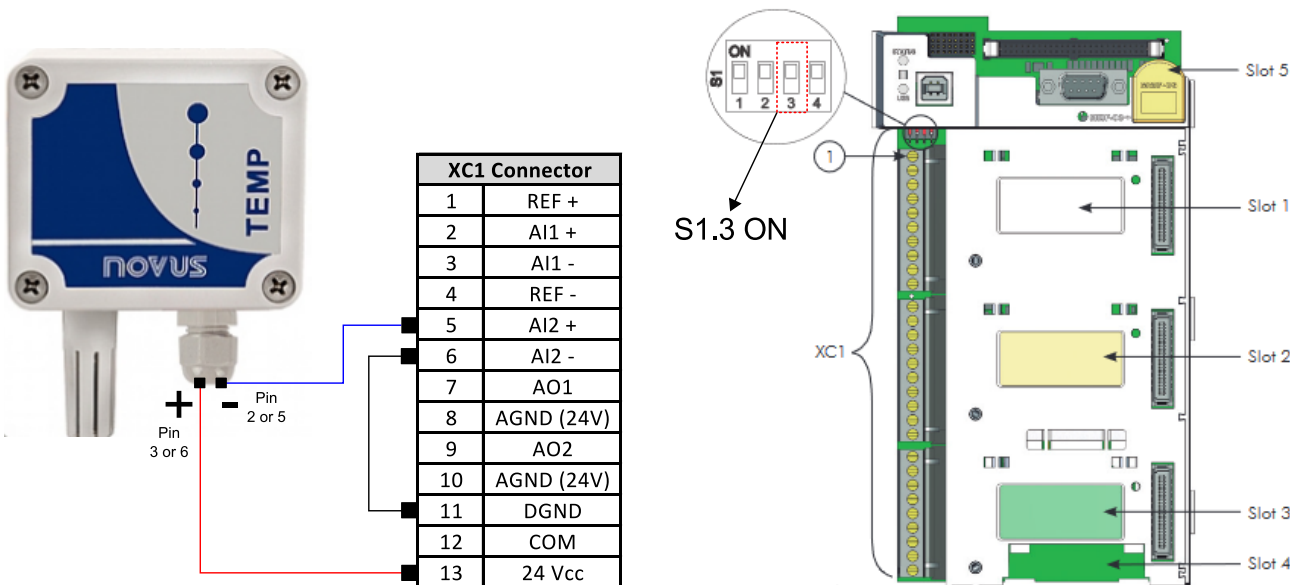

Figure 8.18: Example of connections and setup for Novus TEMP-WM environment temperature sensor with 4 to 20 mA output connected to AI2 of the CFW11

With the connections made, it is possible to select it as the environment temperature sensor for the drive. Just open the asset's thresholds page and go to the "Ambient temperature data source" option. Select "Drive Analog Input" as the data source. Below, select "Inverter Analog Input 2". Finally, you must scale the temperatures. In this case, set 0% analog input to 0°C temperature and 100% analog input to 100°C temperature. The settings are illustrated as per Figure ??.

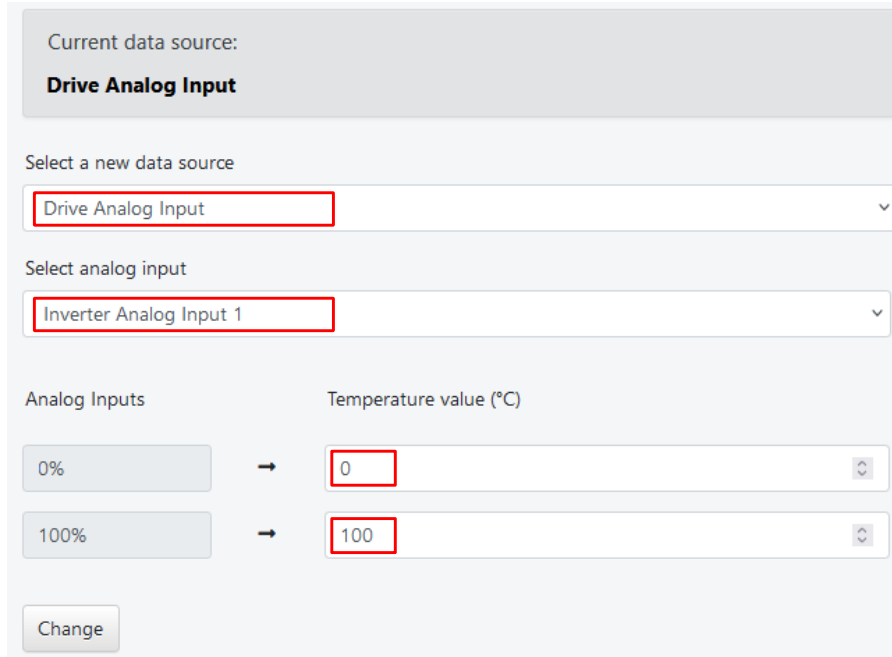

Figure 8.19: Selecting analog input 2 as ambient temperature data source on asset thresholds page

c) IOE temperature card:

Another alternative for acquiring the drive’s environment temperature refers to the use of IOE-02 or IOE-03 accessories. The accessories can be connected, respectively, to connectors XC13 and XC14 of the CFW11 control board.

The IOE-02 uses the PT100 as a sensor to perform the measurement. The IOE-03 uses the KTY84 sensor. Each accessory has 5 sensor inputs, only one of which is needed to perform the measurement. Inputs 1 to 5 can be read, respectively, in parameters P0388 to P0392 of the CFW11. Further information about the accessory can be accessed at WEG’s Download Center, searching for “IOE-01, IOE-02 and IOE-03 Module”.

The connection of a three-wire PT100 to the **input 1** of the IOE-02 temperature module is illustrated in Figure ??.

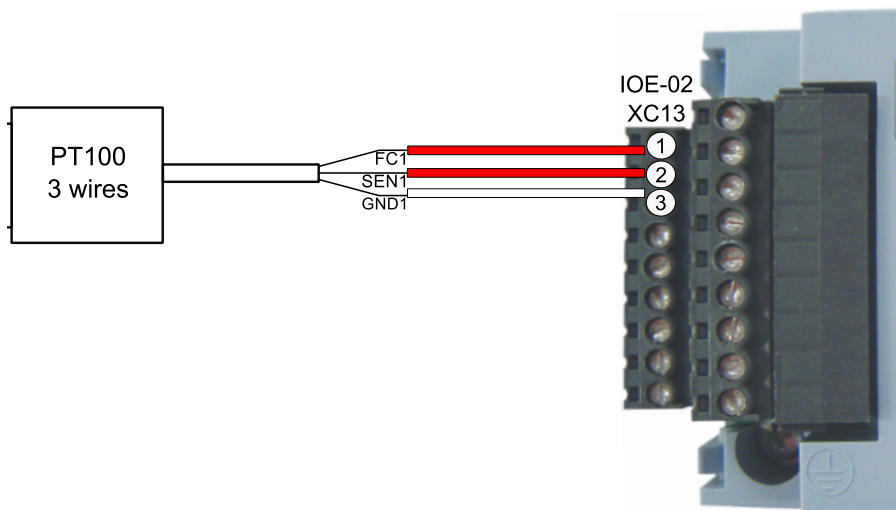

Figure 8.20: Connection between PT100 and IOE-02

To select the IOE as the ambient temperature data source, just open the asset’s thresholds page and go to the “Ambient temperature data source” option. Select “Drive Temperature Card” as the data source. In sequence, one of the accessory inputs must be selected. In the situation illustrated by the Figure ??, input 1 is selected (P0388). The configuration is illustrated as shown in Figure ??.

Current data source:
Drive Analog Input

Select a new data source

Select analog input

Figure 8.21: Selecting temperature card as ambient temperature data source

With the sensing properly configured, it is possible to monitor the ambient temperature through the Ambient Temperature graph, present at the bottom of the Specialist diagnostics page (Figure ??).

Ambient Temperature ⓘ 24/11/2021

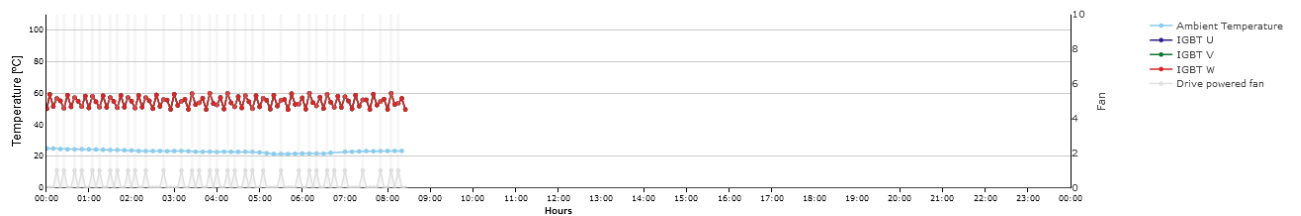

Figure 8.22: Graph of environment temperature values displayed in Temperature Rise Diagnosis (ΔT)

The curves represent, respectively,

- Light blue: recorded values of environment temperature, recorded every 10 minutes (until current time);
- Blue, green and red represent, respectively, the temperature of the IGBT U, V and W. The values are recorded every 5 minutes;
- Gray: fan status (1 for on and 0 for off), recorded every 5 minutes.

A SETTING THE IP ON WINDOWS 10

Step 1 Right-click on the Windows button (formerly “Start”). Click on the “Settings” button (Figure A.1).



Figure A.1: Start button

Step 2 Click on the “Network and Internet” option (Figure A.2).

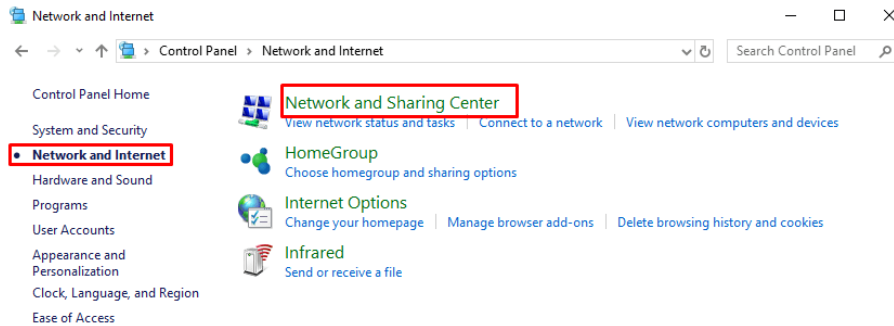

Figure A.2: Network and internet page

Step 3 Click on the “Change adapter settings” option (Figure A.3).

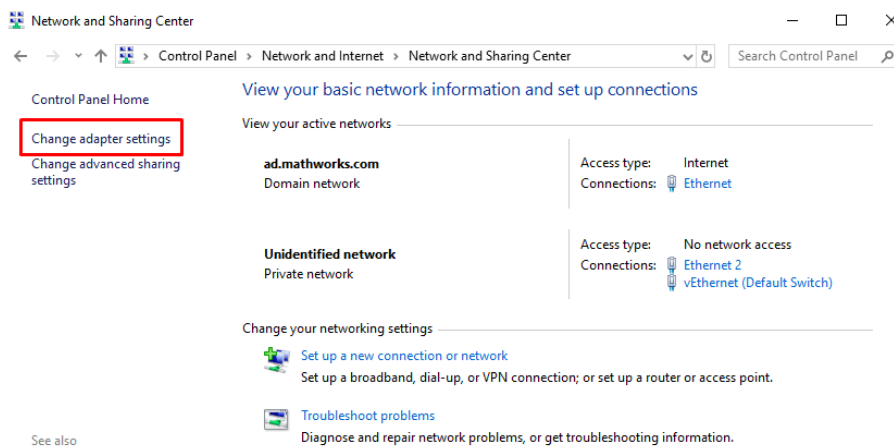

Figure A.3: Changing the adapter

Step 4 Double-click on "Ethernet" (Figure A.4).

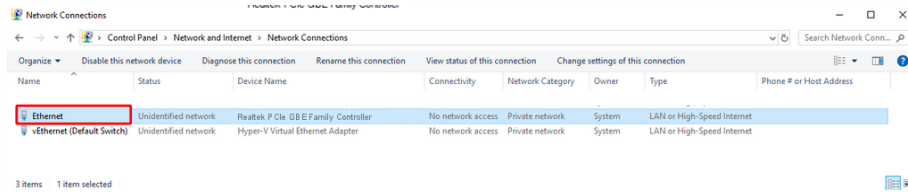

Figure A.4: Selecting the adapter

Step 5 Click on the "Properties" button (Figure A.5).

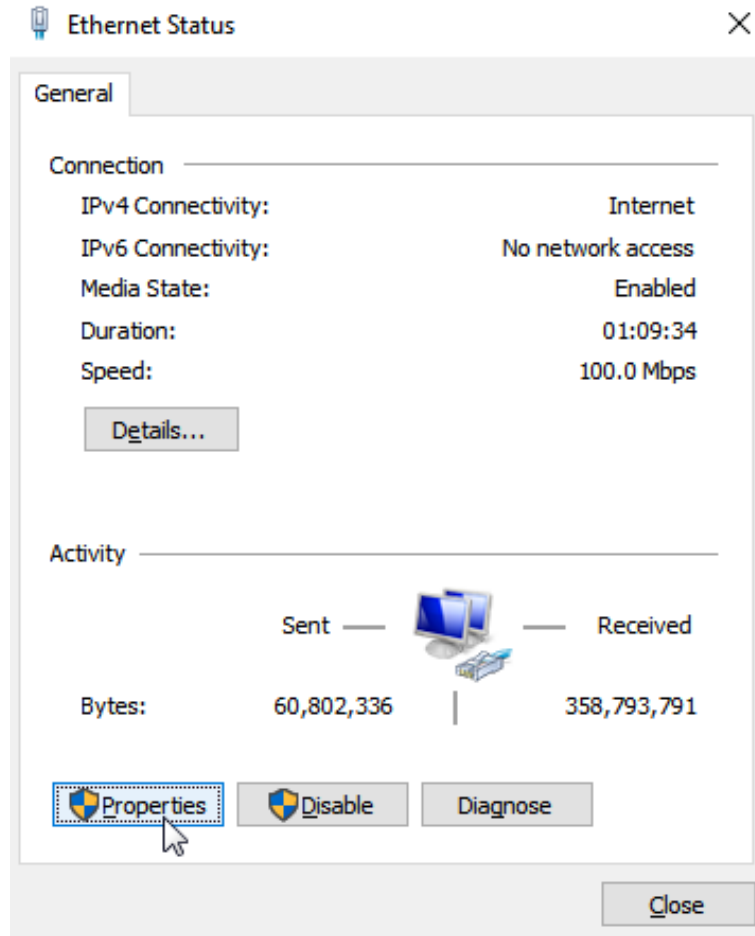

Figure A.5: Changing ethernet properties

Step 6 Select the “Internet Protocol Version 4 (TCP/IPv4)” option. Click on the “Properties” button (Figure A.6).

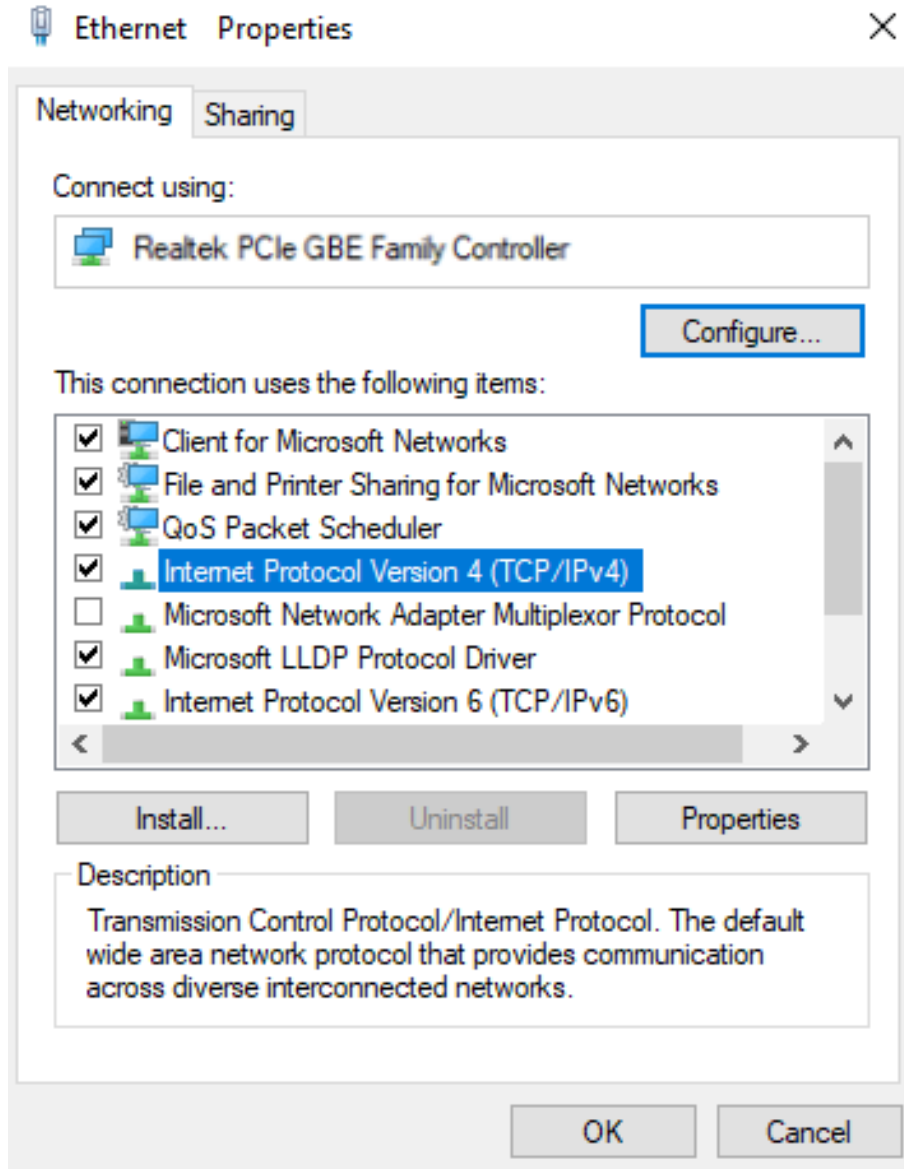

Figure A.6: Selecting IPv4 option

Step 7 Write down the current settings of your network card, because later it will be necessary to restore these settings.
Select the “Use the following IP address” option.
Set the IP address within the same range as the Drive Scan IP; for example, changing the last digit to 20 (or other unused number), resulting in 192.168.0.20.
Change the subnet to 255.255.255.0.

Click on “OK” (Figure A.7).

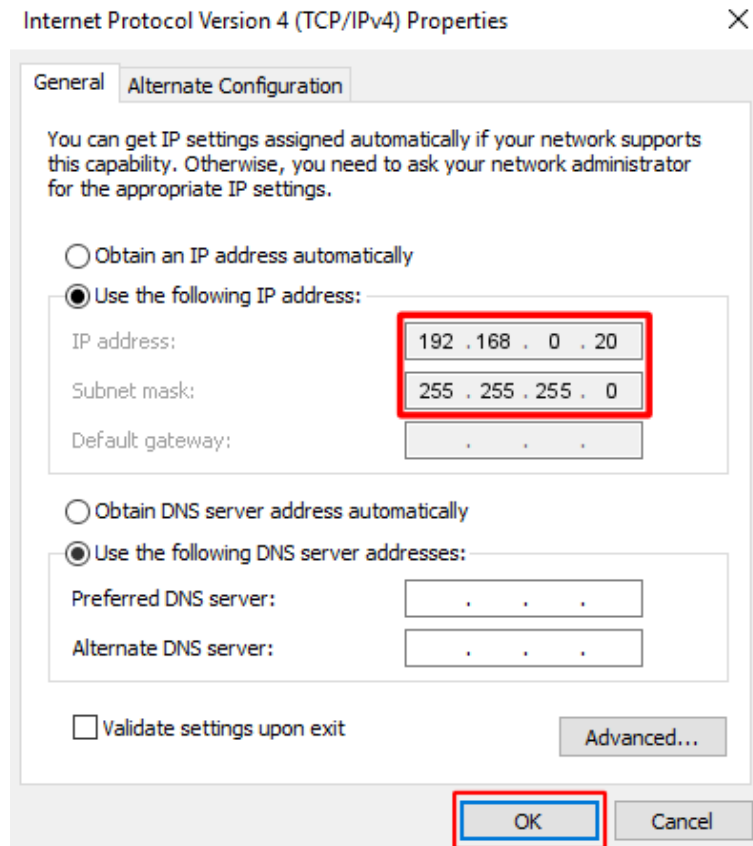

Figure A.7: Changing IP



WEG Drives & Controls - Automação LTDA.
Jaraguá do Sul – SC – Brazil
Phone 55 (47) 3276-4000 – Fax 55 (47) 3276-4020
São Paulo – SP – Brazil
Phone 55 (11) 5053-2300 – Fax 55 (11) 5052-4212
automacao@weg.net
www.weg.net